

# We get technical

---

Matching temperature sensor factors to application needs

---

The evolution of integrated current sensors

---

Using hydrostatic level sensors to improve the efficiency of fresh water processing



# contents



- 3** Magnetic sensing in harsh thermal environments with Allegro Microsystems APS11203/APS12203 Hall-Effect ICs  
Sponsored by Allegro Microsystems
- 5** STMicroelectronics' multi-zone Time-of-Flight sensor enhances spatial awareness in embedded systems  
Sponsored by STMicroelectronics
- 7** Ultrasonic sensors remain the go-to choice for reliable proximity detection  
Sponsored by Same Sky
- 9** Simplifying environmental sensing with factory-calibrated MEMS: a look at Würth Elektronik's sensor portfolio  
Sponsored by Würth Elektronik
- 11** **Special feature: Video spotlight**  
Videos from ams OSRAM, Analog Devices, Murata and Lattice Semiconductor
- 13** **Special feature: retroelectro**  
When structures became too big to guess: the strain gauge story  
  
Ultra-low power FPGAs and Edge AI: The iCE40 family and Lattice sensAI bring intelligence to battery-powered devices  
Sponsored by Lattice Semiconductor
- 16** Matching temperature sensor factors to application needs  
Sponsored by Analog Devices
- 18** The evolution of integrated current sensors. A digital leap with the first Sigma-Delta bitstream output ICS
- 20** Using hydrostatic level sensors to improve the efficiency of fresh water processing
- 22** **Special feature: techtimeline**  
This month in history
- 25**

## Editor's note

### Welcome to the DigiKey eMagazine Volume 31 – Sensors.

This volume opens with a feature from Allegro Microsystems examining the APS11203 and APS12203 Hall Effect switch and latch sensors, highlighting their role in delivering robust, accurate magnetic sensing for demanding industrial and automotive environments. STMicroelectronics follows with a deep dive into the VL53L8CX, showcasing how advanced time-of-flight technology enables high-performance distance and presence detection in compact, power-efficient systems.

Same Sky expands the conversation with an overview of ultrasonic sensors, illustrating how non-contact measurement continues to unlock reliable solutions for level sensing, proximity detection, and object recognition. Würth Elektronik then presents its MEMS sensor portfolio, offering a closer look at how motion and environmental sensing can be seamlessly integrated into modern electronic designs.

On the processing side, Lattice Semiconductor explores its iCE40 FPGA family of development solutions, demonstrating how low-power, flexible FPGA platforms help engineers accelerate innovation at the edge. Analog Devices provides valuable guidance on matching temperature sensor characteristics to application needs, addressing a critical design consideration for accuracy, stability, and long-term performance.

We also feature LEM's perspective on the evolution of integrated current sensors, tracing how advances in integration and performance are simplifying power measurement while enhancing safety and efficiency. Rounding out the issue, our application-focused article, "Using Hydrostatic Level Sensors to Improve the Efficiency of Fresh Water Processing," highlights the essential role of sensing technologies in supporting sustainability and effective resource management.

Together, these articles offer a comprehensive look at the technologies driving smarter systems and better outcomes across industries. We hope this issue delivers practical insight and inspiration for your next design challenge.

Sponsored content provided by:



same sky



WÜRTH ELEKTRONIK  
MORE THAN YOU EXPECT

LATTICE SEMICONDUCTOR

ANALOG DEVICES



# Magnetic sensing in harsh thermal environments with Allegro Microsystems APS11203/APS12203 Hall-Effect ICs



Magnetic position-sensing applications all rely on one key requirement: the sensor must trip at the same magnetic flux density whether the surrounding temperature is -40°C or above 100°C. Meeting this requirement can prove to be difficult. The silicon die inside a Hall-effect IC generates a small but persistent offset voltage that drifts as the package heats up, mechanical stress from overmolding shifts the Hall plate response, and the gain of the internal amplifier tracks its own temperature curve. When all three of these drift sources combine, the magnetic operating point of a standard Hall switch or latch can shift by some millitesla, and that shift is often large enough to cause missed detections or false triggers in safety-critical systems.

Allegro Microsystems solves this issue across successive generations of chopper-stabilized position sensors. The new additions to the portfolio, the

APS11203 switch and APS12203 latch, improve the thermal stability, voltage headroom, and design flexibility over earlier models.

## Switches and latches serve different functions

Before looking at the devices in detail, it is worth clarifying the functional difference between Hall-effect switches and latches. Hall-effect switches like Allegro's APS11203 activate the output when the applied magnetic field rises above a defined operating point and deactivate when the field drops below a lower release point; remove the magnet entirely and the output returns to an inactive state. This behavior is suitable for applications where the presence or absence of a

single magnetic pole needs to be detected, e.g., confirming that a seatbelt buckle is latched or a protective cover on an industrial machine has been closed.

Hall-effect latches like Allegro's APS12203 operate differently: a south-polarity field strong enough to exceed the operating threshold pulls the output low, and it remains low even after the south pole is removed. Releasing the output requires the deliberate application of a north-polarity field that exceeds the release threshold. This bi-stable behavior is why latches

are a favored choice for reading alternating-pole ring magnets in brushless DC motor commutation and rotary encoder wheels, where a repeating north-south pattern carries speed, direction, or absolute angular position data.

## Canceling offset where it originates with chopper stabilization

Both the APS11203 and APS12203 integrate Allegro's proprietary chopper-stabilization circuit, a technique the company has refined over three generations of Hall-effect IC design. The basic principle is signal modulation at a high internal clock frequency where a Hall plate is electrically rotated through multiple orientations during each measurement cycle so the desired magnetic signal appears at a consistent frequency, while the unwanted DC offset voltage, which is



The SOT-23-3 packaging of Allegro's APS11203 and APS12203.

Image source: Allegro Microsystems

fixed relative to the physical die, is pushed up to a higher frequency band.

A low-pass filter then strips out the offset and passes the clean magnetic signal. For the engineer, the result is that the magnetic switch points of these devices hold steady across the full junction temperature range because the primary sources of switch-point

A functional block diagram of Allegro's APS11203.

Image source: Allegro Microsystems

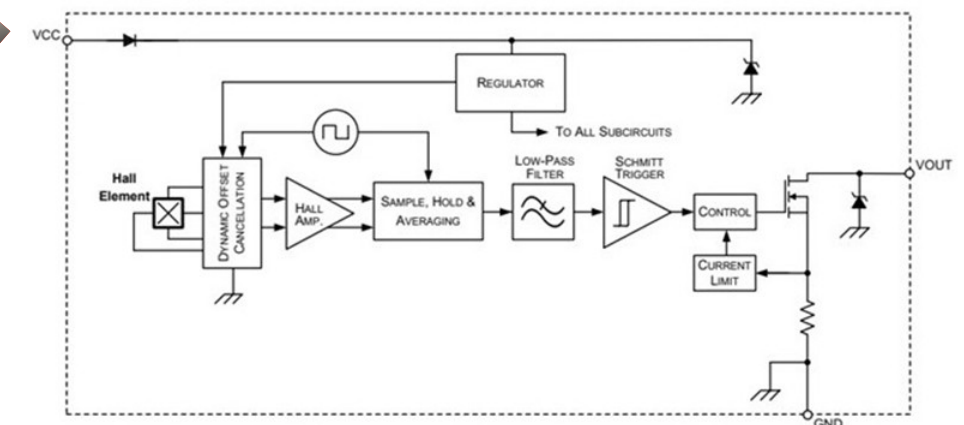



drift have been internally removed. This internal correction also makes the devices less sensitive to any mechanical stresses introduced during reflow soldering and PCB assembly.

### Electrical and magnetic specifications for 24 V architectures

The APS11203 and APS12203 operate from a supply voltage of 2.7 to 26 V, which means a single part number covers both 3.3 V logic-level rails and the 12 V or 24 V bus voltages found in automotive body electronics, industrial control panels, and building automation

systems. The output stage is an open-drain configuration that sources current via an external pull-up resistor, allowing direct connection to microcontroller GPIO inputs and PLC discrete input cards without additional level-shifting components. Both devices carry the full AEC-Q100 qualification and support junction temperatures up to +165°C, making them suitable for under-hood locations like throttle and valve position sensing and gear-shift selector detection.

The APS11203 switch family offers multiple ordering variants including unipolar and omnipolar magnetic response modes. The unipolar versions respond to one polarity,

with south-sensing and north-sensing options available, although south-sensing is the usual choice when a single bar or disc magnet provides the trigger field. On the other hand, omnipolar versions respond to either magnetic polarity. Within each mode, high-sensitivity and low-sensitivity switch-point grades are available, allowing designers to trade off air-gap distance against noise immunity. Output polarity options also allow engineers to match the active-low or active-high convention of the target system without the need for an external inverter. APS12203 latches also provide the same configurability, with multiple

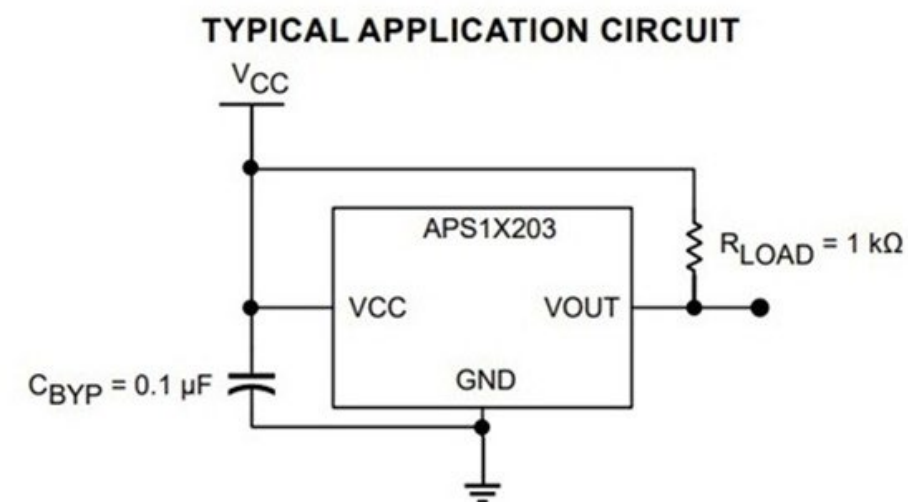

A typical application circuit for Allegro's APS12203.

Image source: Allegro Microsystems

switch-point grades and output polarity options designed for bipolar sensing of alternating-pole magnet arrays.

### EMC and ESD protection in demanding applications

Deploying a Hall-effect sensor next to motor windings, relay coils, or high-current switching circuits exposes every pin to conducted and radiated interference that can corrupt the magnetic measurement or, in the worst case, damage the silicon. The APS11203 and APS12203 address this with built-in protection features like output short-circuit current limiting on both devices, while the APS12203 additionally offers reverse-voltage and overvoltage protection. Both devices can tolerate reverse supply voltages up to -18 V and an absolute maximum supply voltage of 28 V.

For applications that require stricter system-level EMC qualifications, such as powered ESD testing to ISO 10605, conducted immunity testing per ISO 7637-2 and ISO 16750-2, and bulk current injection testing per ISO 11452-4, designers can supplement the basic application circuit with additional passive filtering on the output. Moreover, since the chopper-stabilization circuit already rejects low-frequency noise and DC offset, the external filtering only needs to attenuate the high-frequency transients that fall outside the chopper's cancellation bandwidth, keeping the additional component count minimal.

### Package options and key applications

Both the APS11203 and APS12203 are available in the SOT-23-3

surface-mount package, a three-pin form factor that takes up minimal board space and works with standard pick-and-place equipment and reflow profiles. The packaging is Pb-free and RoHS-compliant. From a BOM perspective, the on-chip voltage regulator, short-circuit-protected output, and solid-state reliability of these ICs keep the external component count to a supply-bypass capacitor and a pull-up resistor, making the total solution cost competitive vs. older, less-stable alternatives.

Combining high-voltage operation, AEC-Q100 qualification, and thermally stable switch points, the APS11203 and APS12203 are [suitable for a wide range of applications](#). In automotive body electronics, these devices can detect seatbelt buckle engagement, door and trunk ajar status, steering lock position, and wiper home position. Industrial usage includes end-of-travel detection on linear actuators, cover-open safety interlocks on machinery, proximity sensing for building automation equipment, and encoder feedback on brushless motors driving conveyor lines. They are also applicable in consumer applications, such as lid-close detection in laptops and appliances to motor commutation in cordless power tools and HVAC blower fans.

Visit the [APS11203/APS12203 product page](#) to identify the device that best suits your system requirements.



An autonomous vacuum cleaner.  
Image source: Adobe Stock

## STMicroelectronics' multi-zone Time-of-Flight sensor enhances spatial awareness in embedded systems



Consumer electronics, smart building equipment, industrial machinery, and mobile robots all need to understand not just whether something is nearby, but where it sits within a scene and how far away it is. For example, a robot vacuum that can only detect an obstacle directly ahead will still collide with a chair leg approaching from the side. A smart display that wakes when a hand waves in front of it but cannot tell whether that hand swiped left or right also makes for a frustrating user experience. A building automation sensor that reports occupancy as a binary output cannot distinguish between one person seated at a desk and three people sitting around a conference table.

Standard proximity sensors fall short of these demands in multiple ways. For example, infrared reflectance sensors return a signal proportional to reflected IR intensity, but their readings vary with target color, surface finish, and ambient light conditions, making them unreliable without extensive per-application tuning. Single-zone Time-of-Flight sensors can measure an absolute distance that is independent of target reflectance, but they collapse the entire field of view into one distance value and therefore cannot localize objects spatially. Ultrasonic rangefinders work across a wider set of surface materials but have relatively slow update rates, wide beam angles that make it difficult

to pinpoint small objects, and blind zones at close range.

**STMicroelectronics' VL53L8CX sensor** combines Time-of-Flight distance measurements with multi-zone spatial resolution in a single miniature module, providing a low-resolution depth map of the scene in front of the sensor.

### Multi-zone Time-of-Flight changes the design equation

Time-of-Flight sensing works by emitting a short pulse of infrared light from a vertical-cavity surface-emitting laser (VCSEL) and measuring how long it takes for that light to return after reflecting off objects. Since the measurement depends on photon travel time rather than reflected signal intensity, the resulting distance reading is absolute and remains consistent regardless of a target's color or surface reflectance, unlike reflectance-based sensors that

must be calibrated for each target surface.

The VL53L8CX expands this principle from a single distance point to either a grid of 64 independent measurement zones in an 8 x 8 matrix, or 16 zones in a 4 x 4 matrix, across a 45° x 45° square field of view (65° diagonal). Each zone returns its own distance reading, and the sensor's patented histogram algorithms enable it to detect and track multiple objects at different distances within the same zone. If two objects sit at different distances along the same line of sight (a wire-mesh fence in front of a wall, for example), the histogram will show two distinct peaks, and the sensor reports both distances rather than averaging into one ambiguous value.

The VL53L8CX's histogram processing offers excellent cover-glass crosstalk immunity beyond 60 cm, which simplifies housing design for consumer products where the sensor is behind a



STMicroelectronics' VL53L8CX sensor. Image source: STMicroelectronics

protective window. The result is a low-resolution depth map, updated at rates up to 15 Hz in 8 x 8 mode or up to 60 Hz in the faster 4 x 4 mode, that captures enough spatial information for the host microcontroller to make zone-based decisions about obstacle locations, occupant patterns, gesture direction, or container fill levels. The 940 nm VCSEL emission is invisible to the human eye and carries a Class 1 laser safety certification, allowing the sensor to be utilized in consumer products without safety enclosures or warning labels.

### Applications configurations for robotics, building automation, and gesture control

The VL53L8CX communicates over both I<sup>2</sup>C (up to 1 MHz) and SPI (up to 3 MHz), with the SPI option useful for applications that require fast host data transfers and reduced initialization time. This is a huge advantage, since the sensor loads approximately 84 KB of firmware at startup, a transfer that SPI completes considerably faster than I<sup>2</sup>C. Moreover, since the sensor handles all histogram processing and distance computation internally, a host MCU receives pre-processed zone distance data rather than raw photon counts, which helps to keep the computational load low enough that even a modest Cortex-M0+ or Cortex-M4 class device can

manage the sensor alongside other system tasks.

In a mobile robot or autonomous vacuum cleaner, mounting the VL53L8CX on the front or side of the chassis can provide an 8 x 8 depth grid covering the forward path. Zone-based obstacle detection can also distinguish between a wall (filling multiple zones at a consistent distance), a narrow chair leg (appearing in one or two zones against a more distant background), and where a floor drops off, like a staircase (where the lower zones suddenly return to longer distances). Additionally, cliff detection, small-object avoidance, wall tracking, and floor-type recognition can all be implemented with zone-comparison logic on the host MCU, with a frame rate up to 15 Hz in 8 x 8 mode or up to 60 Hz when the application can operate in 4 x 4 mode. This feeds the control loop updated scene data at a rate appropriate to the chosen configuration to adjust heading and speed in real time.

Building automation and retail environments are also potential use cases that require a different configuration. Here, mounting the VL53L8CX on a ceiling or above a doorway and pointing it downward can turn the 8 x 8 grid into a presence and occupancy map of the floor below. Since the sensor measures absolute distance and is unaffected by clothing color or ambient lighting variation, it can reliably count the number of

people in a zone, track movement direction for entrance and exit counting, and distinguish between occupied and empty desks for controlled ventilation and lighting. Moreover, its low-power mode and programmable distance threshold also allows the sensor to remain in a sleep state and wake the host only when someone enters a defined range.

As part of STMicroelectronics' STGesture platform (which includes the [STSW-IMG035](#) turnkey gesture-recognition software and the Gesture EVK development tool), the VL53L8CX can also provide the spatial precision needed for gesture-based interaction with smart displays, lighting controllers, and other appliances. Pairing the multi-zone distance data with AI models from the [STM32ai-modelzoo](#) on GitHub can extend the interaction vocabulary beyond simple directional swipes to include "FlatHand," "Fist," and "Like" gestures drawn from eight hand-posture classes in ST's pre-trained VL53L8CX hand-posture dataset.

### What designers need to know before integrating the VL53L8CX

Sensor placement and field-of-view alignment are some of the most crucial considerations in any VL53L8CX integration. The 45° x 45° square projection defines the detection area at a given distance, so designers can model



the coverage footprint for their mounting height and angle early in layout to confirm that the zones of interest align with the regions where detection is required. The VL53L8CX's cover-glass crosstalk immunity, consistent beyond 60 cm by the histogram algorithms, improves optical housing designs by allowing the sensor to operate behind a shared cover glass without using an isolated optical window, though the glass opening must meet or exceed the receiver exclusion zone dimensions specified in the datasheet to avoid clipping the outer zones.

On the software side, STMicroelectronics provides a free driver, API, and evaluation software ecosystem that drastically reduces the integration time. The [P-NUCLEO-53L8A1 evaluation kit](#) pairs the sensor with an STM32 Nucleo board for rapid prototyping,

and the reference software can be migrated to custom hardware with minimal modifications since the driver abstracts the I<sup>2</sup>C/SPI transport layer. The sensor's built-in motion indicator reports per-zone motion intensity values, which allows the host to detect that a target has moved and, by tracking which zones register activity across sequential frames, determine the direction of that movement.

### Coming soon: the VL53L9CX

Teams building around the VL53L8CX today will also want to keep an eye on what comes next. STMicroelectronics has announced the VL53L9CX, a next-generation 3D lidar camera module expected to become available in early-to-mid 2026. Not just a modest iteration, the

VL53L9CX will provide scaling to up to 2,268 zones (54 x 42), a 9-meter ranging capability, dual VCSELs, an integrated postprocessing SoC, and combined depth and 2D IR image output in a larger module. Although the VL53L8CX and VL53L9CX are not software or hardware-compatible, the ToF system design experience and familiarity with STMicroelectronics' FlightSense ecosystem from VL53L8CX development will serve as a good foundation for evaluating the newer device.

### Conclusion

Going from single-point distance measurement to multi-zone spatial awareness has been one of the most noteworthy improvements in embedded sensing in recent years. Compressing what amounts to a 64-pixel depth camera into a 6.4 x 3.0 mm reflowable module that draws modest current, runs at 60 Hz, and outputs data over a standard serial bus, allows the VL53L8CX to provide the spatial intelligence needed to build smarter robots and more responsive human-machine interfaces without the cost, complexity, or power overhead of camera-based or scanning lidar solutions.

For additional information on the VL53L8CX's specifications and other resources, please visit the [VL53L8CX Time-of-Flight Sensor product page](#).



# Ultrasonic sensors remain the go-to choice for reliable proximity detection

same sky

Proximity sensing is designed to simply determine whether an object is present or not. Determining how far away it is, that's another story. The real world throws up a wide range of obstacles that make distance measurement more difficult than it might appear. For instance, factory floors tend to fill with airborne dust and welding flash. Warehouse conveyors contain products ranging from matte cardboard to glossy shrink wrap to transparent glass bottles, often on the same line. Outdoor equipment also needs to function exactly the same under direct sunlight as in complete darkness. In all of these conditions, the challenge of a design engineer is to determine which sensor technology will deliver consistent and accurate readings regardless of the target surface and the environment.

For a wide range of applications, the answer has been ultrasonic sensing, and the technology's relevance has only grown as autonomous vehicles, industrial robotics, and smart logistics systems have expanded the demand for non-contact detection. The working principle is elegant and simple: a transmitter emits a burst of high-frequency sound (usually between 23 and 40 kHz) that reflects off whatever surface it encounters, and a receiver captures the returning echo. By measuring the round-trip time of flight and applying the speed of sound, the system calculates distance with

good accuracy and no physical contact with the target.

Moreover, since the measurement always depends entirely on acoustic energy rather than light or electromagnetic radiation, it remains immune to the visual properties that hamper optical and infrared sensors. A white wall, a black conveyor belt, and a clear acrylic panel all reflect sound waves in essentially the same way, which is exactly the kind of material-agnostic reliability that keeps ultrasonic sensors at the center of so many sensing architectures.

**Same Sky** (formerly CUI Devices) brings deep expertise in this space with [a broad portfolio of ultrasonic transmitters](#), receivers, and transceivers designed to serve various applications, from industrial automation to rugged outdoor vehicle guidance.

## How ultrasonic sensing stacks up against the alternatives

While no sensing technology is universally superior, ultrasonic detection occupies a favorable position when the full spectrum of real-world deployment challenges is considered. Photoelectric sensors, for example, work with opaque, consistently colored targets. However, their readings can become unreliable when surface reflectivity varies or the

target is transparent, and they can be blinded by direct sunlight or overwhelmed by ambient infrared radiation. Laser rangefinders deliver a very wide range and response speed, but consume far more power, cost more per channel, and have eye-safety compliance considerations that add more complexity and potential regulatory issues. Inductive proximity sensors are excellent for detecting metallic objects at close range, but they are essentially 'blind' to plastics, glass, wood, liquids and most other non-ferrous materials, and their effective working distances are measured in millimeters rather than meters.

Ultrasonic sensors sidestep all of these limitations by operating on a principle that utilizes solid and liquid surfaces as a reflector. Their cost per channel remains low, they emit no light (making them effective in total darkness or full daylight), and they can fire hundreds of chirps per second to maintain a high measurement refresh rate, even when tracking fast-moving targets.

## Beam behavior and design implications

One characteristic that distinguishes ultrasonic sensing from laser-based measurement is the way an acoustic wavefront behaves as it travels away from the sensor face. Rather than being tightly collimated like a laser beam,

## Ultrasonic sensors remain the go-to choice for reliable proximity detection



Same Sky offers a range of ultrasonic transmitters, receivers, and transceivers.  
Image source: Same Sky

the sound pulse spreads outward in a 'cone-shaped' pattern, widening its coverage area as the distance increases, much in the same way ripples expand outward when a pebble drops into still water. Sensor makers call this spreading behavior the 'beam angle'. Same Sky ultrasonic sensors span from a focused 7° up to an expansive 80°.

The choice of beam angle has several implications for system performance. A narrow beam concentrates acoustic energy along a tighter corridor, enabling detection at longer distances and providing more precise positional information about where the target lies within the field of view. On the other hand, a wider beam sacrifices some of that directional precision in exchange for broader area coverage, which is useful in general presence detection, collision avoidance zones, and applications where the target might approach

from a range of angles. For design engineers, understanding this tradeoff early in the design process helps them to choose the right sensor configuration without over-engineering or under-specifying the detection geometry.

### Same Sky's ultrasonic sensor portfolio

The wide range of Same Sky's ultrasonic portfolio gives engineers room to optimize rather than compromise. Transmitters reach detection distances up to 18 meters with operating frequencies from 23 to 40 kHz and beam angles at 60°, 75°, or 80°. They are housed in compact aluminum or plastic cases in through-hole, wire-lead, and wire-lead-with-connector mounting styles. The receivers also offer a wide range of specifications, while the transceivers extend frequency coverage from 25 up to 400 kHz

with beam angles from 7° to 80°. In terms of size, package dimensions start as small as 9.8 x 9.8 x 7 mm. Voltage ratings are from 60 to 500 Vp-p across the portfolio, and operating temperatures range from -40 to +85°C depending on the specific model.

For environmental reliability, several Same Sky [transceiver models carry IP67 or IP68 ingress protection ratings](#), meaning sensor housings are sealed against dust ingress and can withstand temporary or continuous immersion in water. For applications in food and beverage processing where washdown cycles are routine, outdoor agricultural equipment exposed to rain, mud, and fertilizer dust, or marine and subsea monitoring, this level of protection eliminates common sources of failure.

### Configuration options: paired vs. integrated

Same Sky offers ultrasonic sensors in two main configurations, and the decision between them greatly impacts the design's cost, footprint, and performance. The first option pairs a dedicated transmitter with a separate receiver, positioned adjacent to each other in the final assembly. This arrangement delivers the smallest achievable blind zone, the minimum distance at which the sensor can produce a valid reading, since the brief ringdown period after the transmitter fires has less

overlap with the receiver's listening window. Separate pairs also offer better sensitivity for detecting faint echoes in acoustically noisy environments. When selecting a matched pair, keeping the rated frequencies of the transmitter and receiver within 1 kHz of each other ensures the best possible signal coupling.

The other option is an integrated transceiver that combines both functions in a single housing. The main benefit here is simplicity and compactness: one component to source, one footprint on the PCB, and one mounting hole in the enclosure. However, the trade-off is a somewhat larger blind zone of roughly 30 cm for standard-frequency models, due to the fact that the same element must finish transmitting before it can begin listening for the echo. However, higher-frequency transceivers can narrow this gap to approximately 5 cm, which is more than adequate

IP-rated ultrasonic transducers for use in harsh environments.  
Image source: Same Sky



## Ultrasonic sensors sidestep all of these limitations by operating on a principle that utilizes solid and liquid surfaces as a reflector.

for most industrial distance measurements where the target sits well beyond the minimum range.

### Where ultrasonic sensors are making the biggest impact

Applications for ultrasonic sensing technology cuts across a range of industries and use cases. Manufacturing and warehouse automation systems use ultrasonic arrays along conveyor lines and at pick-and-place stations to detect product presence, verify stacking heights, and trigger diverters regardless of packaging material or color. Mobile robots

and autonomous guided vehicles (AGVs) also use ultrasonic sensors arranged in rings or arcs to build real-time obstacle maps, navigate narrow aisles, and stop safely when personnel enter their path. Tank and silo level monitoring also benefits from non-contact ultrasonic measurement since the sensor sits above the media surface, eliminating the risk of contamination and preventing mechanical wear.

In automotive systems, ultrasonic parking sensors have become nearly universal, scanning for nearby obstacles over a wide angular range and operating as effectively at night as in bright conditions. Lastly, in personnel safety applications around heavy machinery, these sensors are helping to detect the presence of humans, while not being fooled by changes in clothing color, high-visibility vests, or ambient light, reducing the likelihood of nuisance trips.

To browse their offering of ultrasonic transmitters, receivers, and transceivers and identify the right sensor for your application, visit [Same Sky's Ultrasonic Sensors product page](#).

# Simplifying environmental sensing with factory-calibrated MEMS: a look at Würth Elektronik's sensor portfolio



Designers building connected products need accurate environmental data baked into their systems, but the path from raw physical measurements to usable digital output is typically not straightforward. Analog sensor designs typically require external amplifiers, anti-aliasing filters, reference voltage sources, and painstaking calibration routines that inflate component counts, stretch development timelines, and introduce failure points that can erode accuracy over time. For teams building IoT endpoints, building management infrastructure, or portable monitoring instruments, each added stage represents an engineering effort that could be better directed toward differentiating the end product rather than re-solving signal conditioning problems that have been solved many times before.

[Würth Elektronik](#) offers a viable alternative through its [MEMS environmental sensor portfolio](#), a family of compact digital devices that capture temperature, humidity, and absolute pressure with high accuracy and minimal external support. The sensors are built on micro-electro-mechanical systems (MEMS) technology, which allows the sensing element, analog-to-digital conversion, calibration coefficients, and digital interface logic to coexist on a single silicon die. An immediate benefit is that the sensor's output comes fully

calibrated and temperature-compensated over a digital I<sup>2</sup>C (or, in some cases, SPI) bus, and ready for a host microcontroller to use without any intermediate conditioning circuitry.

## How on-chip processing eliminates external conditioning

To understand what problems the MEMS design solves, it helps to consider what a standard analog sensor signal chain looks like. A pressure transducer, for example, produces a mV-level output that typically requires a precision instrumentation amplifier, a low-pass filter to suppress noise, an ADC with a stable voltage reference, and a lookup table or polynomial correction in firmware to translate the raw digital count into a calibrated engineering unit. Moreover, one of these blocks must be selected, laid out on a PCB, tested, and maintained across the product's lifetime.

Würth Elektronik's MEMS devices collapse this entire chain into the sensor package. Whether the core sensing mechanism is a piezoresistive membrane responding to barometric pressure

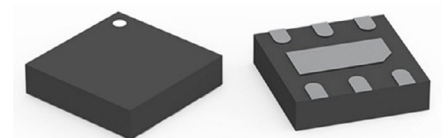

The WSEN-TIDS temperature sensor IC.  
Image source: Würth Elektronik

or a capacitive polymer absorbing water molecules in proportion to ambient humidity, the on-chip ASIC digitizes the raw signal, applies factory-stored calibration data, compensates for temperature drift, and offers the finished measurement through a standard serial interface. Designers can route a two-wire I<sup>2</sup>C bus from the sensor to the microcontroller, pull up the lines with a pair of resistors, and read the calibrated data.

### WSEN-TIDS: precision temperature measurement in a small footprint

The [WSEN-TIDS](#) from Würth Elektronik occupies just 2.0 x 2.0 x 0.55 mm of board space but delivers 16-bit temperature readings across a -40 to +125°C measurement window. Within this span the device holds accuracy from ±0.7°C (typical) to ±1.0°C (maximum), and in the -10 to +60°C band from ±0.25°C to ±0.5°C, which covers the vast majority of indoor, wearable, and near-ambient monitoring scenarios. Output data rates are also user-selectable up to 200 Hz through the I<sup>2</sup>C interface.

In terms of power, the WSEN-TIDS draws only 1.75 µA and operates from supply voltages as low as 1.5 V (up to 3.6 V), making it ideal for coin-cell and small-lithium-battery designs where thermal monitoring can run continuously for months or years without service. A configurable interrupt output adds

further efficiency by allowing the sensor to wake the host processor only when the temperature crosses a programmed threshold, so the microcontroller can remain in deep sleep until a meaningful event actually occurs. Key applications include PCB hot-spot detection inside power supplies, cold chain compliance logging for pharmaceutical and food shipments, climate regulation in HVAC zones, and skin-temperature tracking in wearable health devices.

### WSEN-HIDS: humidity and temperature sensing in one package

Where the WSEN-TIDS focuses on temperature alone, the WSEN-HIDS adds relative humidity measurement alongside an onboard temperature channel within a 2.0 x 2.0 x 0.9 mm package. The humidity sensing element is a capacitive polymer structure whose dielectric constant shifts as water molecules are absorbed or released in response to changing ambient moisture levels. An integrated ADC digitizes both humidity and temperature channels, and the sensor applies internal calibration and temperature compensation before providing the finished readings over an I<sup>2</sup>C or SPI interface, eliminating the need to add firmware correction algorithms.

Accuracy sits at ±3.5% RH across the 20% to 80% relative humidity range which is suitable for comfort

monitoring, process control, and storage environment applications, with measurement updates at millisecond-scale intervals. Operating temperatures range from -40 to 120°C, which covers everything from frozen warehouse environments to high-temperature curing ovens.

Another key feature of the WSEN-HIDS is the built-in heater element. If condensation forms on the polymer surface during a temperature swing or a move between climate zones, the heater activates, driving off the film of moisture and restoring valid readings within seconds rather than waiting for passive evaporation. Applications for the WSEN-HIDS include building automation nodes, agricultural greenhouse monitors, data loggers, and portable IoT sensing platforms.

### WSEN-PADS: absolute pressure sensing with onboard intelligence

Würth's [WSEN-PADS](#) rounds out the environmental trio with a piezoresistive absolute pressure sensor in a 2.0 x 2.0 x 0.8 mm holed land grid array footprint. Its measurement window covers 26 to 126 kPa with 24-bit output resolution, and users can select data rates from 1 to 200 Hz, depending on whether the priority is power savings or rapid response. An integrated ASIC and onboard temperature sensor provide

factory-calibrated output values, ensuring accurate pressure data.

What differentiates WSEN-PADS from typical pressure transducers is the processing capability built into the device. A 128-level FIFO buffer accumulates pressure and temperature samples internally, meaning the microcontroller does not need to poll the sensor at every output interval and can instead retrieve batched data at its own convenience. Apart from buffering, activatable on-chip algorithms also pre-process the raw measurements for specific use cases and offload work from the connected controller. The device is rated for the full industrial temperature range of -40 to 85°C. Applications for WSEN-PADS include altimeters, barometers, weather stations, GPS navigation, indoor navigation, white goods, and wearable devices.

### Pairing sensors with wireless modules for end-to-end IoT

A sensor that delivers clean digital data is valuable on its



The WSEN-HIDS humidity sensor with integrated temperature sensor. *Image source: Würth Elektronik*

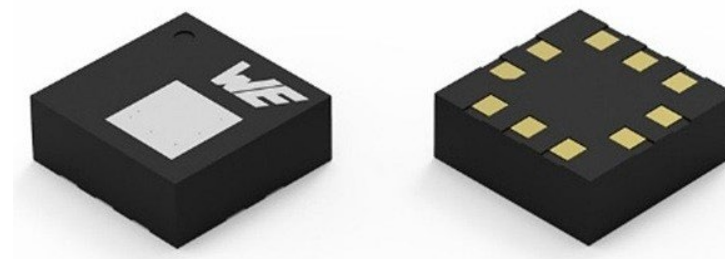

The WSEN-PADS absolute pressure sensor. *Image source: Würth Elektronik*

own, but that impact multiplies when that data can reach cloud analytics platforms, dashboards, and enterprise software without needing custom networking development. Würth Elektronik built its sensor/wireless connectivity portfolios to work hand-in-hand, creating a streamlined path from physical measurement to the cloud. The Calypso Wi-Fi module provides IEEE 802.11 b/g/n connectivity with a fully integrated [TCP/IP stack](#), built-in support for MQTT and HTTPS, and security features spanning encrypted sockets, authenticated boot, protected storage, and over-the-air firmware updates.

For applications that need something other than Wi-Fi, the portfolio extends to Bluetooth Low Energy (Proteus series), LoRaWAN long-range mesh (Daphnis-I), and cellular LTE-M/NB-IoT (Adrastea-I), allowing designers to match the radio technology to their project's range, throughput, and power budget. The [Calypso IoT Design Kit](#) demonstrates how all of these elements work together. Built around the Feather form factor, the

kit stacks a [sensor FeatherWing](#) (carrying temperature, pressure, humidity, and acceleration sensors) with a [Calypso Wi-Fi FeatherWing](#) to create a sensor-to-cloud prototype. Since the FeatherWing ecosystem is open-source and stackable, teams can swap in different radio modules, add display boards, or attach external sensors through the QWIIC connector without redesigning the base platform.

### Conclusion

Each MEMS sensor in Würth Elektronik's portfolio ships with an evaluation board for verifying its performance and accelerating early-stage prototyping. The Sensors Software Development Kit provides portable C-code drivers compatible with common host MCUs, and comprehensive user manuals and application notes (including detailed guidance on MEMS sensor PCB design and soldering) are freely available.

To explore how these sensors can streamline your next environmental monitoring design, visit the [Würth Elektronik Sensor Portfolio](#).

# Video spotlight

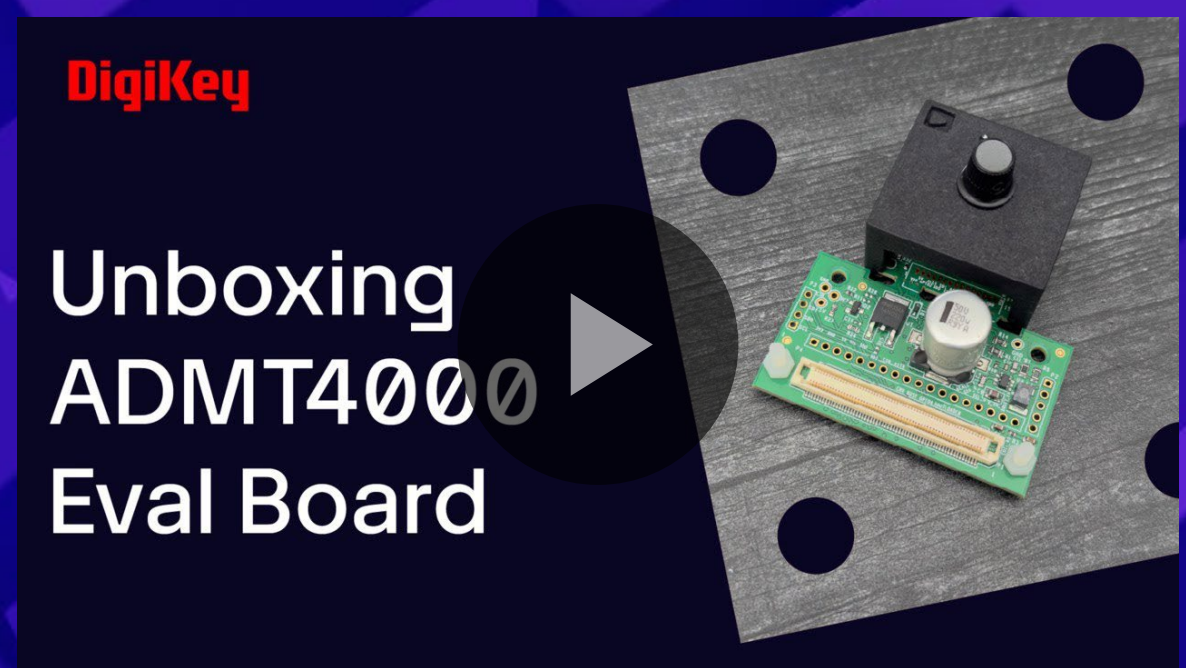
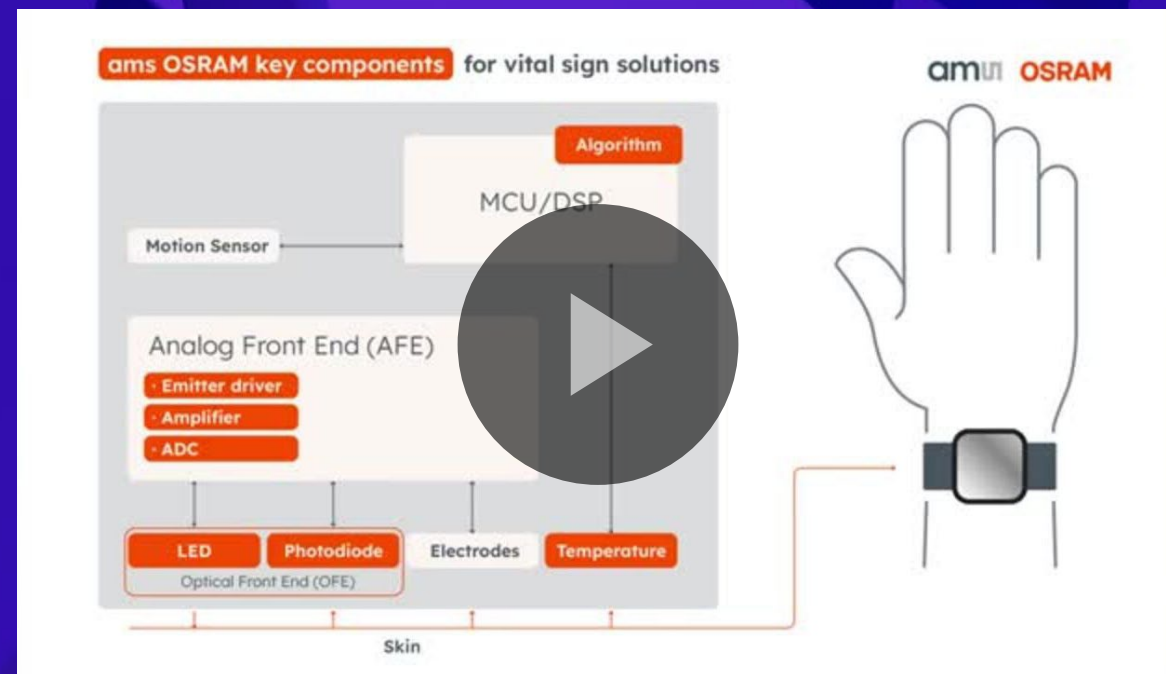

## Vital Sign Monitoring

ams OSRAM vital-sign monitoring advances, featuring a high-performance analog front end and improved emitter technology. The reference design enhances accuracy for wearables like smartwatches, supported by optimized algorithms for precise, reliable health tracking.

[Learn more](#)



## Analog Devices ADMT4000 Evaluation Board

This demo showcases the ADMT4000 eval board and its GMR Multiturn technology as it tracks absolute angle and rotation - even with power removed. Using the SDP-S controller and PC software, the system displays live position data, powers the sensor off, and still resumes with perfectly accurate turn and angle counts the moment power returns.

[Learn more](#)

# Video spotlight

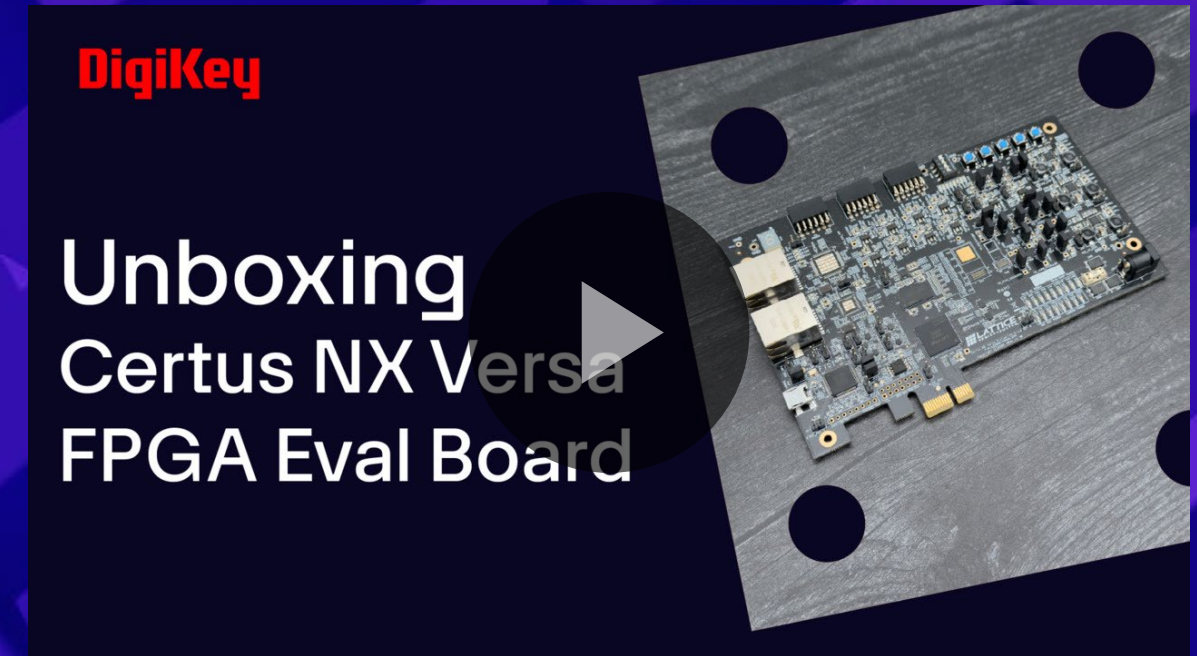
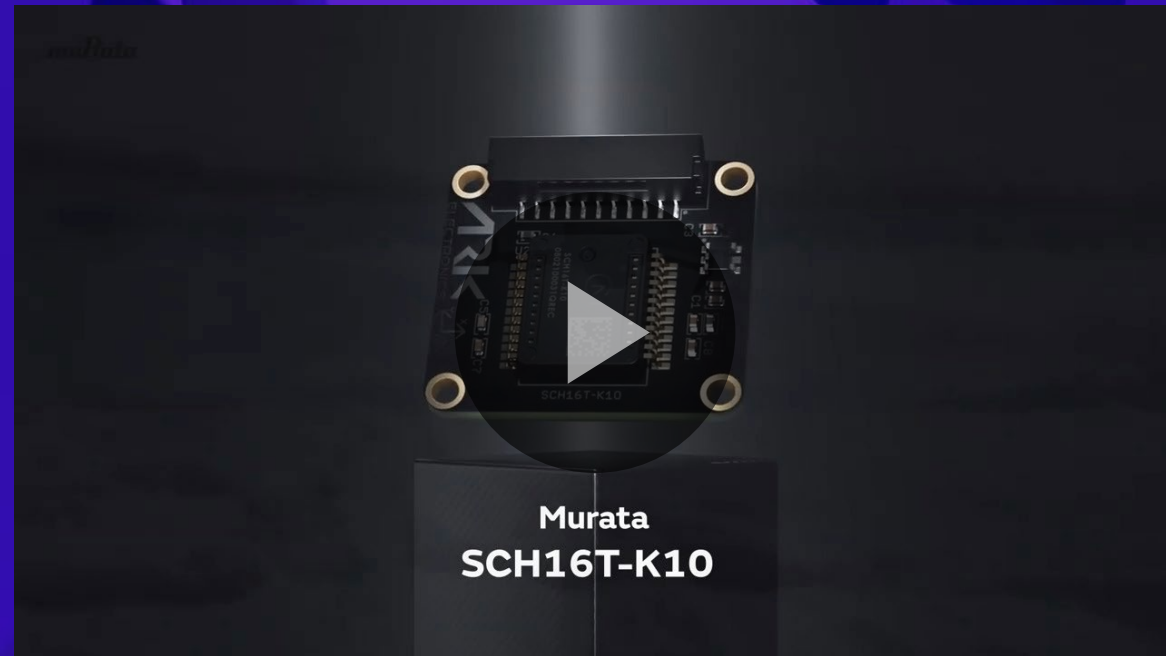

## SCH16T-K10 Sensor

Discover the Murata SCH16T-K10, a high-performance 3-axis gyroscope and accelerometer built on capacitive 3D-MEMS technology. This video highlights its 6-DoF sensing capabilities, excellent stability, low noise, and suitability for demanding motion-control and industrial applications.

[Learn more](#)



## Certus-NX FPGA Eval Board

Explore the Certus-NX Versa FPGA Evaluation Board from Lattice Semiconductor as DigiKey unboxes the kit and highlights its key capabilities. The video showcases the board's rich feature set, built around the low-power, high-performance Certus-NX FPGA, designed to support versatile development and prototyping needs.

[Learn more](#)

# When structures became too big to guess: the strain gauge story

By: David Ray, Cyber City Circuits

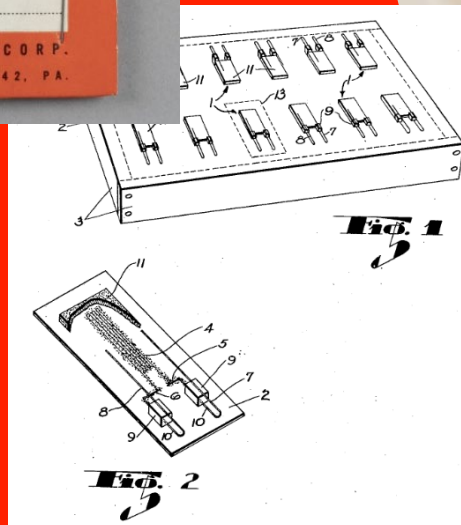
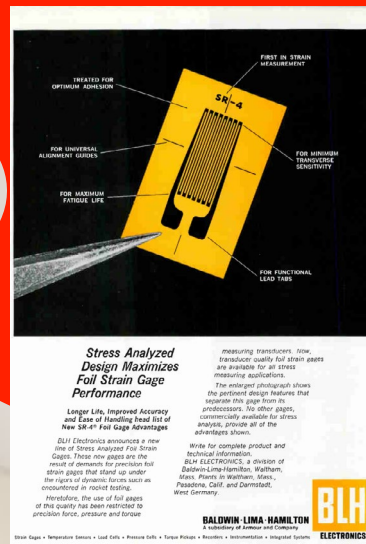
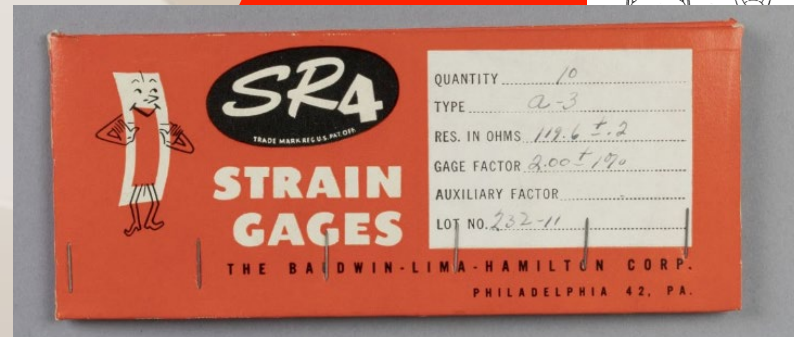
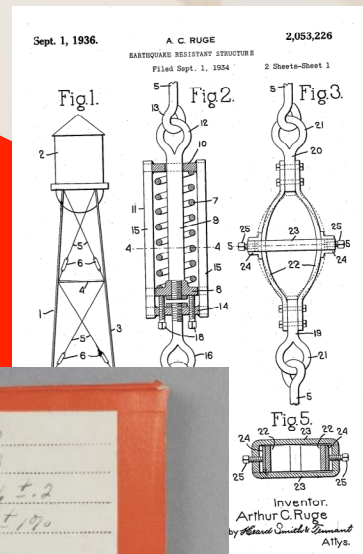

## Building bigger means failing bigger

The turn of the twentieth century brought a lot of new tools with it. For the first time, skyscrapers were being built, massive bridges connected lands that had never been linked before, and machines became large enough that failure was no longer small or forgiving. Engineers could calculate loads and create detailed stress diagrams, but once steel met rivets and concrete faced gravity, those calculations disappeared inside the structure. What remained unresolved was whether those stresses could be observed directly rather than inferred, without destroying the structure to do so.

Engineers could calculate stress, but they had no reliable way to measure it inside a working structure without altering the structure itself. Every available method, mechanical extensometers, optical levers, or fixtures, either added stiffness, required reference frames, or failed under dynamic loads. The core problem was not sensitivity, but non-interference: How to observe strain while becoming effectively invisible to the structure being measured?

## On the measurement of forces within bodies

Men had been trying to solve this problem for a very long time, long before steel frames and rivet guns

made it unavoidable. Robert Hooke was the first to give the problem a name. In the seventeenth century, his straightforward principle, Hooke's Law "ut tensio, sic vis" (which means "as the extension, so the force"), formalized that deformation itself carried information. The amount of stretch can tell you the amount of force. Even with this breakthrough in pre-Victorian forensics, Hooke could only describe the relationship. He had no way to measure it inside a real object.

Isaac Newton supplied the mathematics to calculate stress in beams, columns, and cables, turning elasticity and material stress into equations that could be solved on paper. Yet Newton's mechanics remained predictive rather than observational. Again, stress could be found on paper but not measured.

Throughout the eighteenth and nineteenth centuries, engineers tried to figure out how stress affected buildings and bridges. Beams were loaded until they bent, cracked, or failed. Optical levers magnified tiny deflections. Mechanical extensometers clamped onto specimens in laboratories. These tools worked, but only by standing outside the structure or by becoming part of it.

The first real breakthrough came from William Thomson, later Lord Kelvin, while trying to solve problems relating to submarine

**Retro Electro fun fact:** Robert Hooke died in 1703 while serving as president of the Royal Society, and soon after, Isaac Newton took over as president and moved it to a new building. After the move, Hooke's instruments, papers, and any known portraits vanished, fueling a long-running suspicion that Newton, his bitter rival, quietly erased Hooke's image along with his legacy. No proof survives... but neither do any confirmed genuine pictures of Hooke's face.



**Retro Electro fun fact:** William Thomson was later knighted by Queen Victoria for his work on submarine telegraph lines and the Trans-Atlantic Cable. You can find that story in the Retro Electro article 'Wildman Whitehouse and the Twenty-Five-Hundred-Mile-Long Capacitor.'

and the change is reversed. For the first time, mechanical strain left a measurable fingerprint.

Others brushed against the same idea without completing it. By the dawn of the twentieth century, physics was known, mathematics was mature, and the need was undeniable. What was still missing was not sensitivity or theory, but a way to create a sensor that could disappear into a structure,

Huggenberger Extensometer]  
Caption: Drawing of a Huggenberger Extensometer.

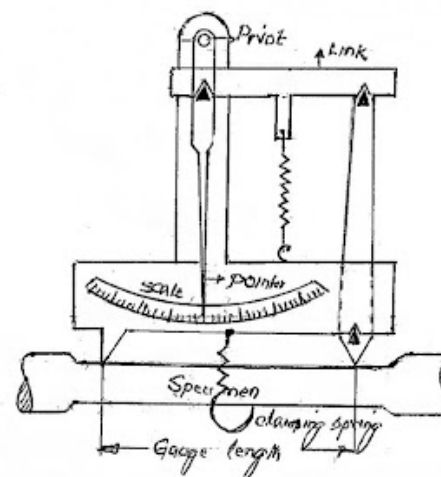

*On the Effects of Mechanical Strain on the Thermo-Electric Qualities of Metals. By Professor W. THOMSON, M.A., F.R.S.*

Having found by experiment that iron and copper wires, when stretched by forces insufficient to cause any permanent elongation, had their thermo-electric qualities altered, but immediately fell back to their primitive condition in this respect when the stretching forces were removed; having remarked that these temporary effects were in each case the reverse of the permanent thermo-electric effects previously discovered by Magnus, as resulting from permanent elongation of the wires, by drawing them through holes in a draw-plate; and thinking it most probable that all these effects depended on mechanical induction of the thermo-electric qualities of a crystal in the metals operated upon; the author undertook an experimental investigation of the thermo-electric effects of mechanical strains, in which he intended to include longitudinal extension, longitudinal compression, lateral compression, and lateral extension, and in each case to test both the temporary effects of strains within the elastic limits of the substance, and the residual alterations in thermo-electric quality, manifested after the cessation of the constraining force, when this has been so great as to give the substance a permanent set. The cycle of experiments has now been so nearly completed for both the temporary and the permanent strains, as to allow the author to conclude with certainty that the peculiar thermo-electric qualities induced in each case are those of a crystal. Thus, he finds that iron bars, hardened by longitudinal compression, have the reverse thermo-electric property to that discovered by Magnus in iron wires hardened by drawing; and that iron wire, under lateral compression, manifests the same thermo-electric property as the author had discovered in iron wire while under a longitudinal stretching force. The apparatus by which these results were obtained was exhibited to the Section, and the mode of experimenting fully described. As regards iron, the general conclusion is, that its thermo-electric quality, when under pressure in one direction, deviates from that of the unstrained metal, towards bismuth for currents in the direction of the strain, and towards antimony for currents perpendicular to 1855.

Excerpt from Thomson's report to the British Association for the Advancement of Science in 1855.

accurately share its deformation, and report what it sensed without altering the results.

**Arthur Claude Ruge**

Born in Tomah, Wisconsin, Arthur C. Ruge graduated from the Carnegie Institute of Technology in 1925. After several years working as a structural steel engineer, he obtained a master's degree in civil engineering and a doctorate in engineering seismology from MIT, where he later became a faculty member. In 1938, while researching the effects of earthquakes on water towers, he invented the strain gauge by attaching a fine wire of

**Retro Electro fun fact:** In 1938, Arthur C. Ruge at MIT and Edward E. Simmons at Caltech independently developed bonded resistance wire strain gauges. Although he had nothing to do with Ruge's work, was not named in Ruge's patents, failed to commercialize his invention, and his patent came later, Simmons is often credited as a co-inventor in the history books.

constantan to the tower using a tube of DUCO modeling glue.

Soon, Ruge left MIT with his assistant, Alfred deForest, and



Ruge and his assistants solving structural stress problems with a model of a water tower. This is likely the same problem that he was working on when he developed the strain gauge.

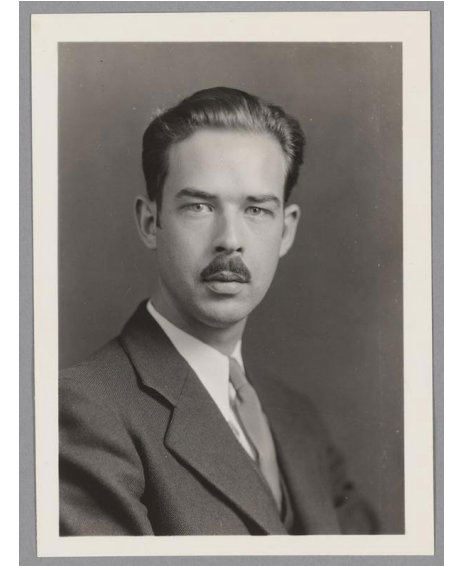

Arthur C Ruge as he looked during this time.

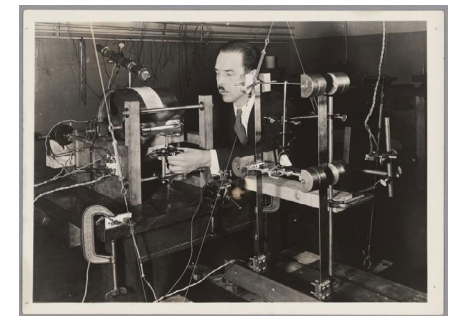

started Ruge-deForest Inc. Through this company, they mass-produced the new SR-4 Strain Gauge. After the strain-gauge division of Ruge-deForest Inc. was bought by their biggest customer, the Baldwin-Lima-Hamilton (BLH) company.

Baldwin-Lima-Hamilton was building trains and machines whose failure modes could no longer be understood from drawings alone. Locomotive frames, axles, and castings

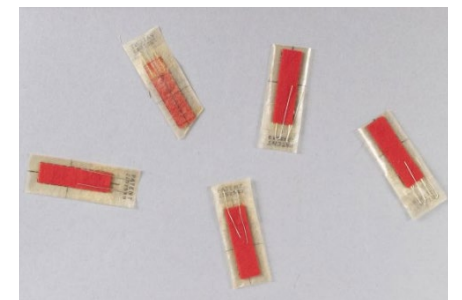

accumulated damage over millions of load cycles, often failing far from the points engineers expected. Calculations explained how forces should flow, but they did not explain where cracks would actually begin. The SR-4 answered that gap directly. It allowed stress to be observed under real operating

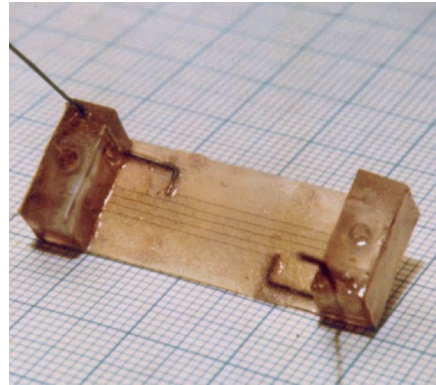

An Example of the 1938 Ruge Strain Gauge that started it all.

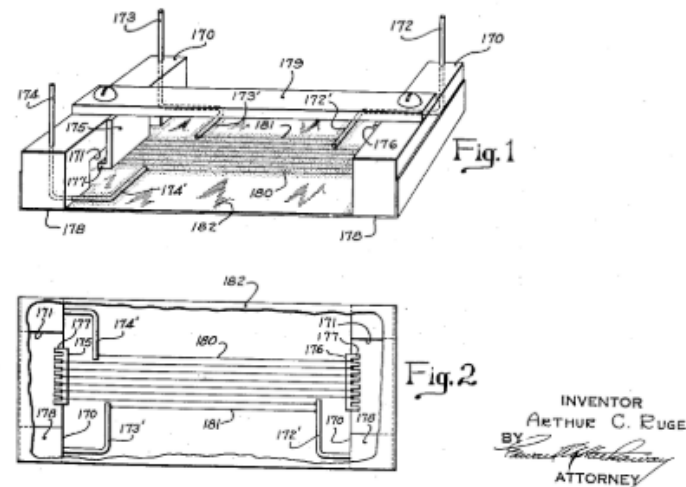

conditions, on real machines, without dismantling them or altering their behavior. In acquiring the SR-4 strain-gauge line, BLH was not diversifying its business so much as keeping a tool it already needed: the ability to see what its machines were doing while they were still intact. Instead of keeping the SR-4 as a proprietary internal tool, they further commercialized it, selling millions of units.

In 1955, a separate, unrelated segment of Ruge's original company, the temperature-sensor business, continued independently. That business eventually became today's RdF Corporation in Hudson, New Hampshire, which focuses on temperature and heat-flux sensors and bears the original founders' initials.

### What changed once stress could be measured

Once strain could be measured directly, it became clear that other mechanical quantities could also be detected. Measurements of pressure, load, torque, and similar factors that induce strain and fatigue in materials could now be converted into electrical signals. Engineering practices changed forever. Structures no longer had to be trusted solely based on calculation and assumption. For the first time, engineers could ask a finished structure what it was experiencing, rather than what theory predicted it should experience.

**Retro Electro fun fact:** Did you know the original Murphy's Law, "If there is any way to do it wrong, he will," was said about a technician when Edward Murphy had a mishap involving a SR-4 strain gauge.



BLH SR-4 Installation Kit

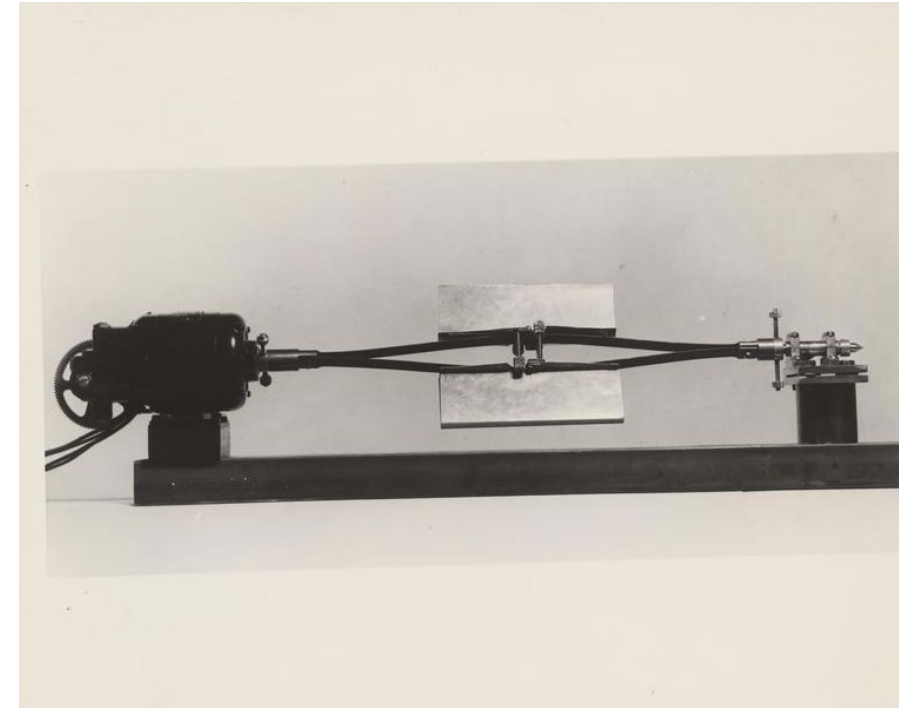

Calculations did not disappear. They simply stopped being the final word. Testing replaces assumptions. Bridges could be tested under live load, aircraft wings could be stressed to failure while every critical point reported its condition, and rotating machinery could be monitored continuously rather than inspected after damage had already occurred. Failure can now be predicted rather than discovered after a structure collapses. Fatigue, once treated as a statistical abstraction, became something that could be watched in real time.

Equally important, strain measurement collapsed a whole bunch of questions into a single observable quantity. Force, weight, torque, pressure, and acceleration could all be reduced to strain and

measured with the same basic technique. Load cells replaced guesswork, and structural testing moved out of the laboratory and into the field. Measurement no longer requires massive fixtures and reference frames when the SR-4 could ride within the structure itself.

A strain gauge is basically a very fine conductor whose electrical resistance changes when it's stretched or compressed. That part was already known long before Ruge, Thomson had shown in the 1850s that straining a metal wire changes its resistance. What Ruge did 'invent' was the realization that if you bond that wire directly to the structure with a thin, stiff adhesive layer, the wire no longer behaves like a separate object. It is forced to deform exactly as the surface

beneath it deforms. The gauge doesn't measure the force applied to itself, instead it borrows the strain of the structure and quietly converts it into a measurable change in electrical resistance. In mechanical terms, the gauge participates in the deformation but contributes essentially nothing to load, stiffness, or strength.

There are currently nearly 1500 strain gauge products found in the Digikey catalog, where all your electronic needs and component desires can be fulfilled.

<https://www.digikey.com/en/products/filter/strain-gauges/559?s=N4lgTCBcDaIM4BcBOBDAIqOwAQHMUFccBTEAXQF8g>

### Suggested reading

- ["Strain Gauge or Strain Gage?" by Morehouse Force](#)
- [EDWARD E. SIMMONS JR, v. CALIFORNIA INSTITUTE OF \(Sept 16, 1949\)](#)
- [ARTHUR C. RUGE AND FLORENCE B. RUGE v. COMMISSIONER OF INTERNAL REVENUE](#)
- ["Strain Gauge – Part 1" by Engineers 4 World](#)
- ["Strain Gauge – Part 2" by Engineers 4 World](#)
- ["Ruge, Arthur Claude" Collection at the MIT Museum](#)
- [RdF Corporate History](#)

# Ultra-low power FPGAs and Edge AI: The iCE40 family and Lattice sensAI bring intelligence to battery-powered devices



Application processors can run complex algorithms, but their power budgets are often too large for products that need to operate continuously on a coin cell or a small lithium-polymer pack. Microcontrollers offer lower power consumption, but their fixed instruction sets and sequential execution pipelines impose hard limits on throughput when handling tasks like real-time image classification, voice keyword detection, or multi-sensor data fusion.

[Lattice Semiconductor's iCE40 FPGA](#) family fills this gap by providing a programmable fabric that executes logic in parallel at clock frequencies low enough to keep total power consumption in the microwatt-to-milliwatt range, while its sensAI solution stack layers an AI/ML development workflow on top of that hardware to help designers move from trained neural network model to deploy

edge inference, without needing FPGA expertise.

## **iCE40 Series: programmable logic built for size and power constraints**

Manufactured on a 40 nm process, the iCE40 portfolio has several sub-families, each optimized for a slightly different balance of density, integration, and power. The iCE40 [LP](#) (low power) and [HX](#) (high performance) series offer between 384 and 7,680 look-up tables of logic with I2C hard IP and a range of BGA and QFN packages, making them suitable for general-purpose interface bridging, GPIO expansion, and voltage translation between mismatched bus standards on a mobile or IoT main board. The iCE40 [Ultra](#) series offers two additional on-chip oscillators (a 10 kHz low-frequency oscillator for always-on housekeeping as well

as a 48 MHz oscillator for burst processing), hard SPI controllers alongside I2C, DSP blocks for sensor data pre-processing, three 24 mA constant-current RGB LED driver outputs, and a 500 mA infrared LED driver output that supports IrDA communication and barcode emulation without an external MOSFET.

The iCE40 [UltraLite](#) shrinks physical footprints even further, shipping in wafer-level chip-scale packages as small as 1.4 x 1.48 mm with a static current draw of approximately 35  $\mu$ A, roughly half that of the Ultra series. For applications where on-device voice recognition or intensive local computation is required, the iCE40 [UltraPlus](#) extends the resource pool to 2,800 or 5,280 LUTs, adds an extra 1 Mbit of single-port SRAM, DSP multiply-accumulate blocks capable of 16 x 16 operations, and two I/O pins that support the I3C interface standard. That combination of memory,

compute, and interface flexibility allows the UltraPlus to run a keyword-spotting neural network locally so the host processor's higher-power audio codec can remain powered down until a valid wake word is confirmed. This design extends battery life by hours in a continuously listening wearable or smart-home endpoint.

The feature that ties all iCE40 sub-families together is their instant-on mode which comes from SRAM-based configuration loaded at power-up through a standard SPI interface or, in devices that include non-volatile configuration memory (NVCM), from one-time-programmable on-chip storage

that eliminates the external flash entirely.

## **Four design categories**

iCE40 supports four broad categories of mobile and IoT system design. The first is enhancing application processor connectivity by providing extra GPIOs to extend the processor's interface capabilities, translating between voltage domains that the processor's native I/O banks cannot support, and aggregating multiple slow serial buses onto a single high-speed link.

Secondly, they help to extend battery life by offloading timing-critical functions, such as sensor polling, LED animation sequencing, and communication protocol handling, to the FPGA so the main

processor can remain in a deep sleep state for longer intervals. The iCE40 also helps to improve overall system performance via hardware acceleration of repetitive or latency-sensitive operations, such as signal conditioning, data formatting, and protocol conversion, which would otherwise take up valuable processor cycles.

Lastly, the FPGA offers flexible interface bridging that allows product teams to select the most suitable companion components for a design whether those components share a common bus standard or not, because the iCE40 can translate between SPI, I2C, I3C, SDIO, and a range of custom protocols in real time.

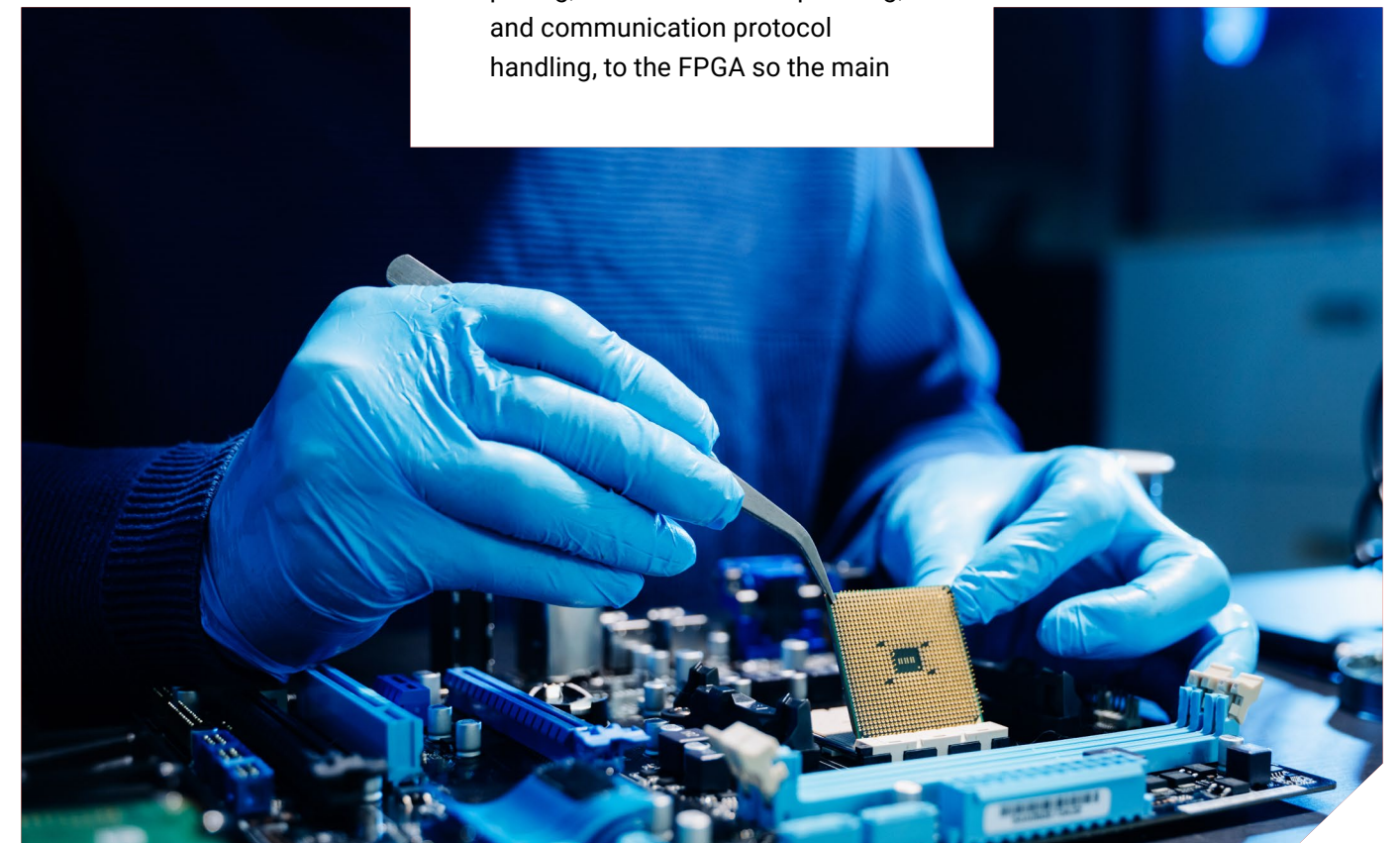

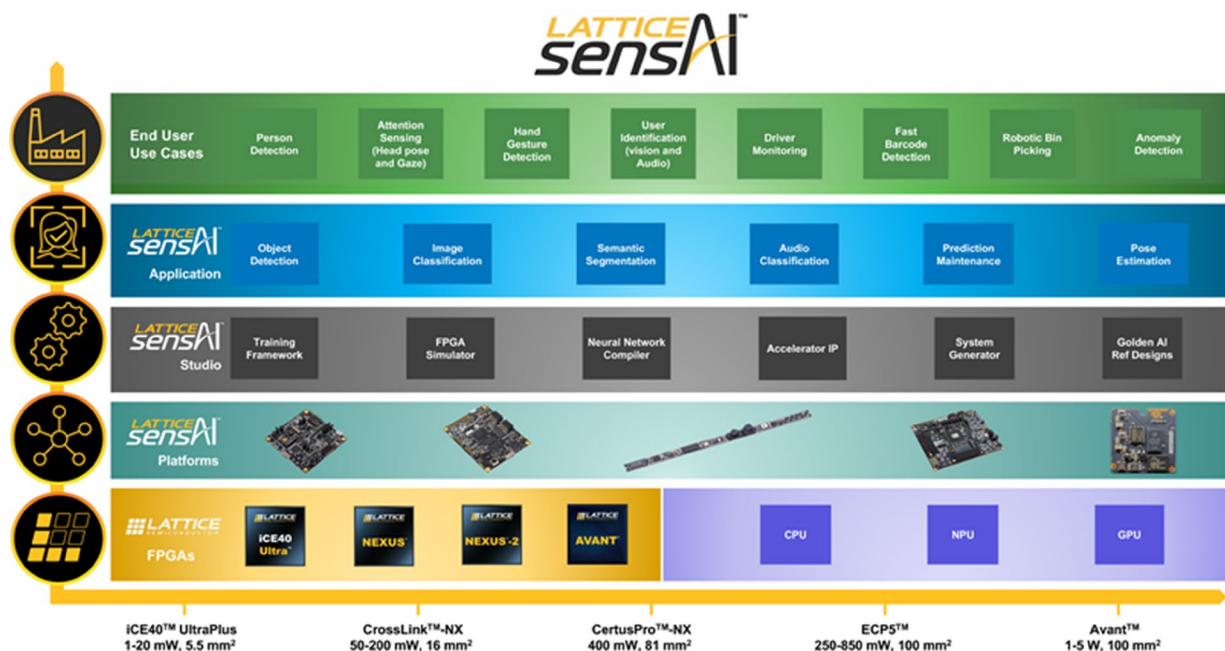

**Lattice sensAI: complete AI/ML stack for low-power edge inference**

While the iCE40 hardware provides the parallel compute fabric that makes low-power inference physically possible, the sensAI solution stack removes the software and workflow barriers that have kept FPGA-based AI out of reach for teams without dedicated RTL engineers. sensAI is a layered collection of hardware platforms, pre-optimized neural

network IP cores, software tools, reference designs, and custom design services that together cover the entire path from model training through on-device deployment.

At the middle of the software toolchain is the [Lattice sensAI Studio](#), a GUI-based environment where developers can select a target FPGA, import a neural network model (from Lattice’s own model library or from external frameworks including TensorFlow, TensorFlow Lite, Keras, and Caffe), apply transfer learning to fine-tune

the model on application-specific data, configure and validate the trained model, and compile it for deployment onto the selected device.

The drag-and-drop interface within sensAI Studio and the companion [Lattice Propel design environment](#) means that system designers who are primarily software engineers, not FPGA specialists, can build a complete FPGA design incorporating a RISC-V soft processor alongside a CNN acceleration engine without writing RTL by hand. TensorFlow Lite inference running on a Lattice FPGA has been shown to execute between 2 and 10 times faster than the same model running on an ARM Cortex-M4 MCU, while drawing much less power since the FPGA’s parallel fabric processes multiple operations per clock cycle at a

**Combining low-power programmable logic and an accessible AI development workflow opens up new design possibilities that neither the hardware nor the software can support alone.**

fraction of the clock frequency the MCU would require.

The [sensAI stack](#) supports hardware platforms across the entire Lattice FPGA lineup, including [CrossLink-NX](#) for embedded vision applications and [CertusPro-NX](#) for higher-accuracy object and defect detection, but the iCE40 UltraPlus occupies a distinct position in the stack as the target for ultra-small, ultra-low-power inference tasks where the total power budget may be measured in single-digit milliwatts. Production-ready reference designs and validated use cases within sensAI include applications like face detection, object counting, gesture control, presence detection, attention tracking, and anomaly detection, all of which can be adapted via transfer learning

and redeployed without modifying the underlying FPGA bitstream architecture.

**How iCE40 and sensAI work together**

Combining low-power programmable logic and an accessible AI development workflow opens up new design possibilities that neither the hardware nor the software can support alone. For example, a laptop OEM can offload presence detection and attention tracking from the main CPU onto an iCE40 running a sensAI model, achieving up to a 28% improvement in battery life compared to CPU-driven AI processing with always-on privacy features like automatic screen dimming when a user looks away.

In an agricultural monitoring system, an iCE40 UltraPlus running a compact image classification model can sort berries or detect crop anomalies at the sensor node, transmitting only actionable results over a low-bandwidth wireless link rather than streaming raw image data to a cloud server. Industrial equipment can use the same platform for vibration-based predictive maintenance inference continuously at the motor or bearing, flagging degradation patterns before they escalate to unplanned downtime.

*To explore the range of iCE40 development solutions, evaluation kits, and sensAI-compatible reference designs for your next low-power edge application, visit the [iCE40 FPGA Family page](#).*

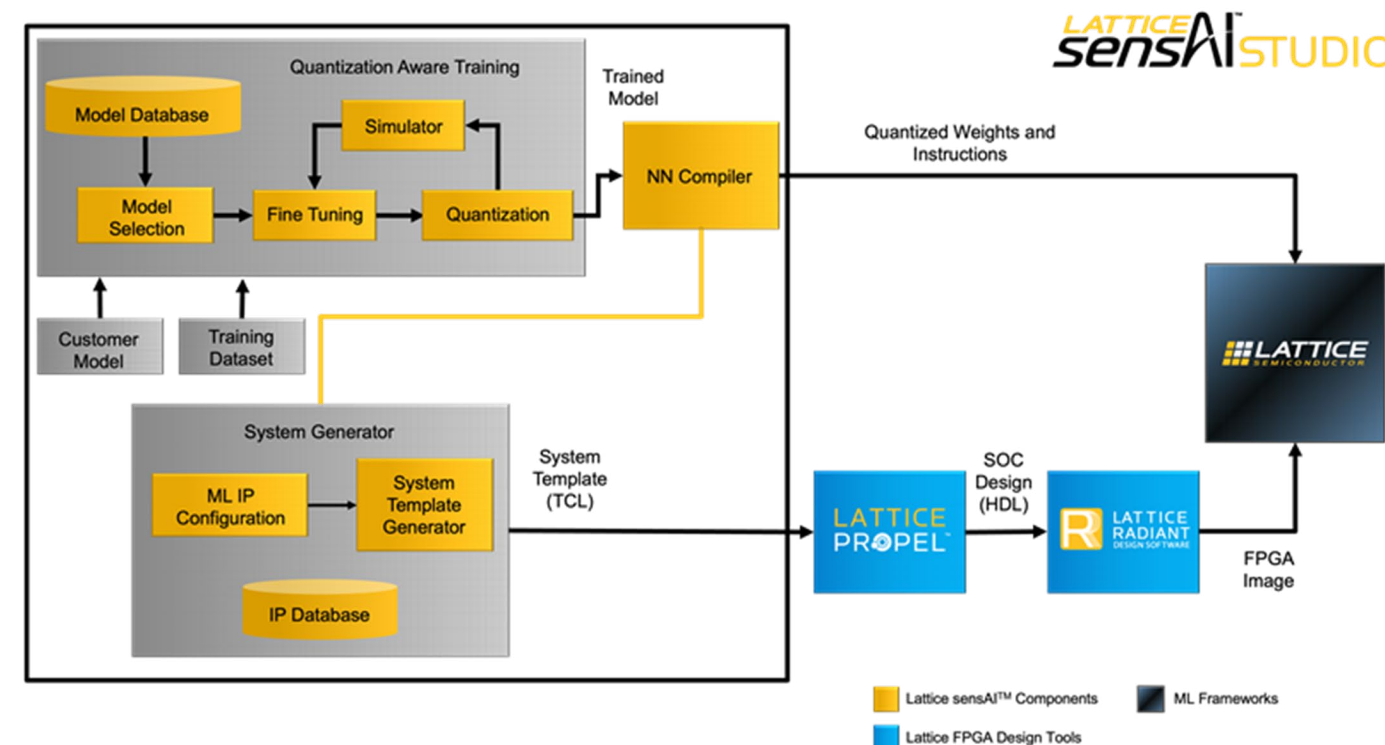

# Matching temperature sensor factors to application needs

By Pete Bartolik



Choosing the optimal temperature sensor for an application can be challenging, given the variety of sensor technologies available and the diverse industry requirements. However, many applications require exact readings, so it is essential to examine the wide range of options that are available.

Selecting a temperature sensor involves balancing multiple factors to meet design requirements such as accuracy, response

time, communication protocol, environmental robustness, power usage, cost, and system integration. Sensors generally fall within four categories of analog voltage output, and a fifth that utilizes a digital signal output:

1. *Thermocouples* have a wide temperature range and durability, measuring from cryogenic temperatures to over 1800°C. They are rugged and can withstand harsh

environments and respond quickly to rapid temperature changes. However, they're less accurate and stable than other options and require signal conditioning. They are well-suited for heavy industry such as steel and glass production, and in-home and commercial appliances with high heat.

2. *Resistance temperature detectors (RTDs)* are highly accurate and stable. They're

ideal for industrial automation and process control where precision is crucial. RTDs are commonly used in the food and pharmaceutical industries for tight temperature control in processes like brewing, sterilization, and frying. They provide accurate temperature measurements for HVAC systems, and in laboratory and medical equipment like incubators and analytical instruments. RTDs can be expensive compared to alternatives like thermocouples, and they are fragile due to their reliance on fine wire or thin film sensing elements. They are often used with a precision measurement circuit that adds to design complexity and cost.

3. *Thermistors* are temperature-dependent resistors made from semiconductors that exhibit high sensitivity. Large resistance changes for small temperature shifts enable the detection of minute fluctuations and high resolution. Small, fast, and low-cost, thermistors are available in various sizes from tiny beads to larger probes. They excel in applications with limited temperature spans, typically between -50°C and 150°C. Thermistors are very versatile, finding use in medical devices and consumer electronics where ambient or body temperature is relevant, as well as automotive applications,

battery management systems, consumer appliances, and fire and smoke detection. However, their non-linear resistance curve requires conversion formulas or lookup tables to translate resistance to accurate temperature, and they may experience drift over time compared to RTDs.

4. *Diode-based temperature sensors* provide fast response times and are smaller than the other three analog types. They can readily interface with a microcontroller, analog-to-digital converters (ADCs), and application-specific integrated circuits (ASICs). They are cost-effective, have a limited temperature range of -55°C to +150°C, and are utilized in a wide range of applications spanning consumer electronics, industrial automation, data center storage systems, automotive, and many others. They exhibit lower accuracy than RTDs, are susceptible to system noise, and often require calibration to ensure consistent readings between different devices.

5. *Digital temperature sensors* are integrated circuits (ICs) that measure temperature and provide a direct digital output, typically over communication protocols like SMBus, I<sup>2</sup>C, SPI, or 1-Wire. They don't require the external signal conditioning, amplification, and analog-to-

digital conversion of the analog options.

## Selection guidelines

Choosing the appropriate temperature sensor involves balancing accuracy, response time, durability, and cost. Industry-specific requirements can also guide the selection of a suitable component.

The operating environment of the application plays a crucial role. Harsh conditions necessitate robust sensors like thermocouples or coated RTDs, while thermistors or semiconductor sensors are

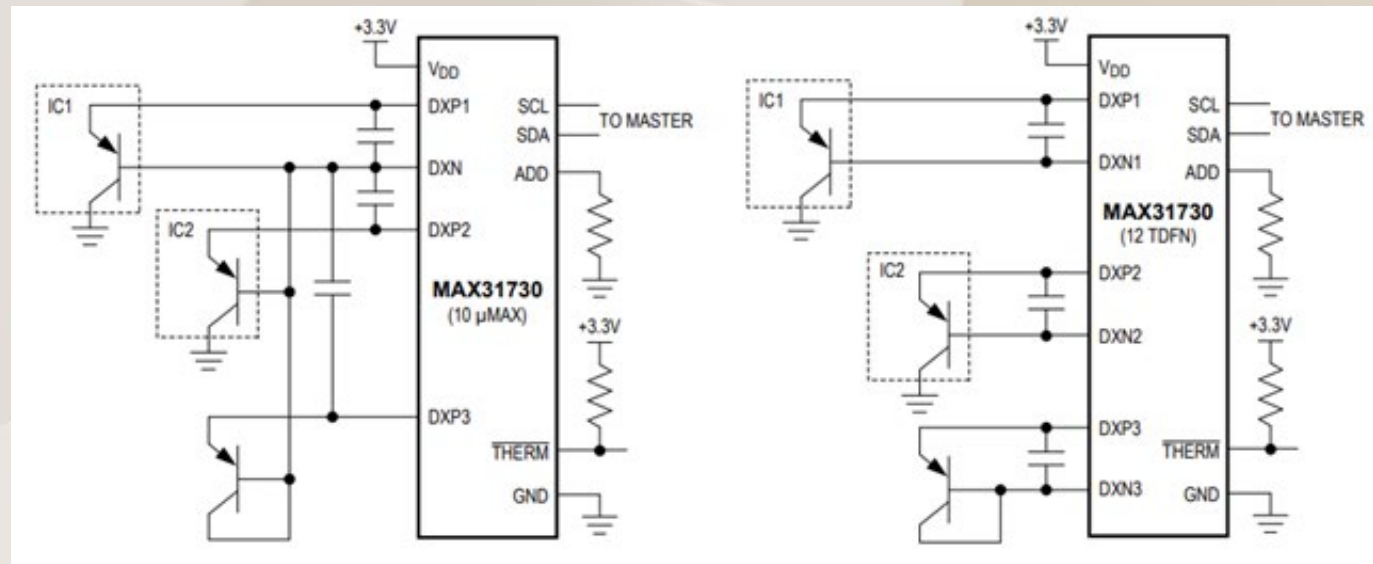
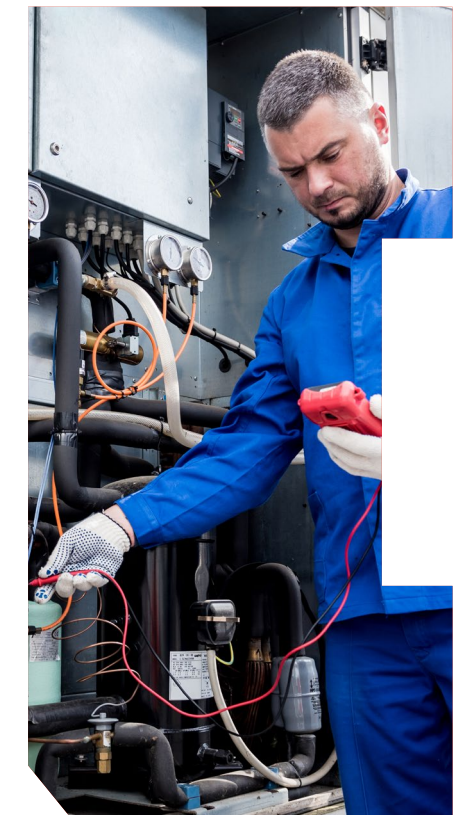

Figure 1: A typical application circuit using the MAX31889 temperature sensor.

Image source: Analog Devices, Inc.



## Matching temperature sensor factors to application needs

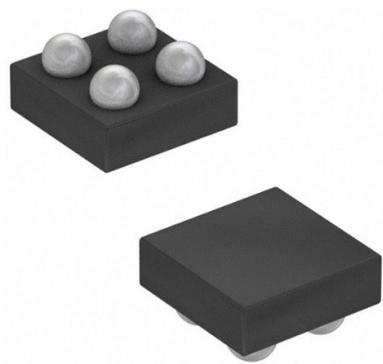

Figure 2: Representation of the MAX31875R0TZS+T form factor. Image source: Analog Devices, Inc.

more suitable for controlled environments. Cost and scalability are also factors to consider in mass production – thermistors are economical, but RTDs and high-end thermocouples offer long-term stability.

The designer's trade-offs between accuracy versus practicality can also impact selection. RTDs provide high precision but are expensive, while thermocouples are more versatile but less accurate. Response time and placement also matter – small, low-mass

sensors like thermocouples and thermistors respond quickly, but their placement can impact performance.

The cost of a sensor and its associated circuitry can heavily influence selection, especially in consumer products or high-volume manufacturing. There is a considerable cost range among sensor types. Analog sensors require signal conditioning, while digital sensors simplify integration. Reducing analog circuitry and calibration can minimize overall costs and justify the use of even a slightly more expensive digital sensor.

### Digital options and characteristics

Digital sensors convert an analog signal internally and transmit data as a digital stream, often providing better noise immunity and enabling more complex data processing. Analog Devices, Inc. (ADI) offers

a broad portfolio of analog and digital temperature sensors, and designers should carefully evaluate which best matches the needs of their application. Following is a brief recap of some digital sensors.

When exact temperature readings are necessary, accuracy is likely the top selection factor. ADI's MAX31889 digital sensor features  $\pm 0.25^\circ\text{C}$  accuracy over a range of  $-20^\circ\text{C}$  to  $+105^\circ\text{C}$ , and communicates with a microcontroller over a 1-Wire bus to enable high-precision temperature monitoring circuits (Figure 1). Programmed into each MAX31888 is its own unique 64-bit registration number, which acts as the node address in a multi-drop 1-Wire network.

The MAX31889 utilizes just one data line for communication, from which it can directly draw parasitic power, eliminating the need for an external supply. When an external power supply is used, its voltage range is from 1.7 V to 3.6 V while consuming only 68  $\mu\text{A}$  of current during measurement.

Power consumption and size may be the top concern when designing small, battery-operated devices. For applications such as wearables, ADI's MAX31875 devices, such as the MAX31875R0TZS+T (Figure 2), combine a very small package size of 0.84 mm x 0.84 mm x 0.35 mm and low supply current consumption with a temperature measurement accuracy of  $\pm 1^\circ\text{C}$ .

The MAX31875 family uses an I2C/

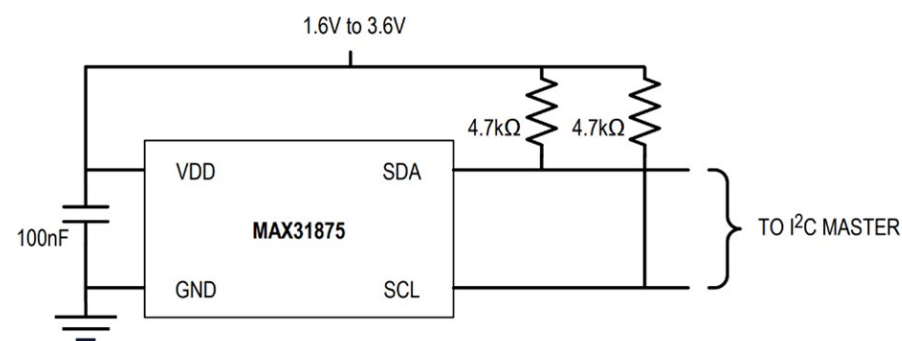

Figure 3: An application circuit using a MAX31875 digital temperature sensor. Image source: Analog Devices, Inc.

## The cost of a sensor and its associated circuitry can heavily influence selection, especially in consumer products or high-volume manufacturing.

SMBus-compatible serial interface that uses standard write byte, read byte, send byte, and receive byte commands to read temperature data and configure sensor behavior in a typical circuit (Figure 3). It uses  $<10 \mu\text{A}$  average power supply current and can measure temperatures from  $-50^\circ\text{C}$  to  $+150^\circ\text{C}$ .

ADI also offers ICs designed to precisely measure the temperature of thermal diodes and convert it into a digital format, replacing conventional thermistors or thermocouples. These remote diode sensors measure the temperature of external PN

junctions, like the thermal diodes built into CPUs, GPUs, FPGAs, and ASICs. While devices such as the MAX6654 measure a single thermal diode, other options are available for 2, 3, 4, and 8-channel applications.

Remote diode sensors can be widely employed in electrically noisy environments with appropriate internal and external filtering. The MAX31730 is a 4-channel temperature sensor that monitors its own temperature along with the temperatures of up to four external diode-connected transistors (Figure 4).

The MAX31730 sensor can be programmed to set temperature thresholds without any special software or firmware. A 2-wire serial interface can be used to monitor temperatures and revise temperature thresholds.

### Conclusion

Finding the optimal temperature sensor can ensure better performance, reliability, and cost-efficiency in an application. Selection can be impacted by a range of factors, including industry-specific requirements and standards, and cost-versus-performance trade-offs. ADI's digital temperature sensor portfolio offers solutions to meet the needs of a wide variety of applications.

For help in choosing an optimal temperature sensor, visit the [Analog Devices, Inc \(ADI\) portfolio](#).

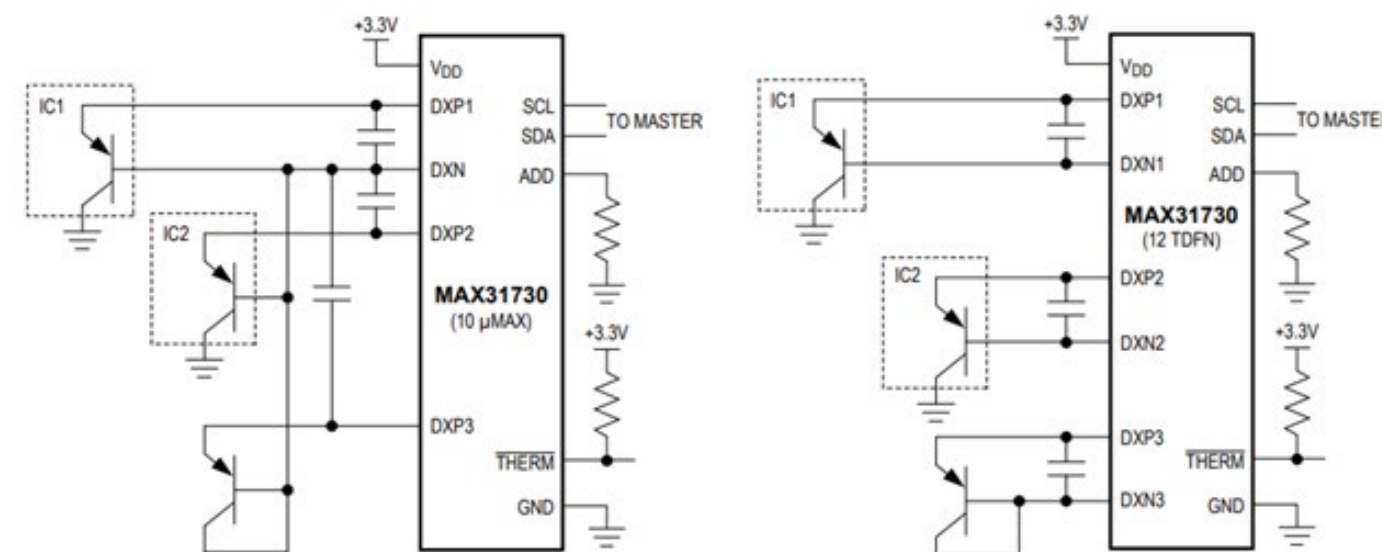

Figure 4: ADI's MAX31730 can monitor up to four external diode-connected transistors as in this application circuit. Image source: Analog Devices, Inc.



# The evolution of integrated current sensors

## A digital leap with the first Sigma-Delta bitstream output ICS

**Integrated current sensors (ICSs)** have steadily evolved since their earliest implementation. Their journey has been less about dramatic revolutions and more about incremental refinements: smaller form factors, improved accuracy, greater robustness in harsh environments, and stronger insulation for high-voltage applications.

### What customers need most: four priorities driving ICS design

Every generation of ICS development has been guided by user needs. Market studies and direct customer engagement consistently highlight four priorities:

1. *Performance over temperature 'range'*

Accuracy across varying thermal conditions is critical. Drift and sensitivity offset can make or break performance, particularly in power electronics where conditions fluctuate rapidly.

2. *Current-handling capability*  
Smaller ICSs save board space and cost, but their integrated primary conductors typically

limit continuous current capacity to around 30-50 amperes (A). Extending this range – without compromising performance or reliability – remains a central challenge.

3. *Over-current detection*  
Protection is essential in applications such as automotive, industrial automation, and renewable energy. Reliable over-current monitoring ensures safety and prevents costly system failures.
4. *'Electrical' Insulation*  
Both basic and reinforced insulation are necessary depending on the application. Effective insulation is critical for compliance and safety in high-voltage systems like electric vehicles and industrial drives.

Any new ICS must address these four fundamentals to succeed in

the marketplace.

### The path to miniaturization

The modern ICS story can be traced through several innovation milestones:

1. *Closed-loop Hall effect ICSs*  
These early designs used Hall effect sensing combined with custom application-specific integrated circuits (ASICs). They offered high accuracy and strong insulation but came at higher cost.
2. *Open-loop ICSs*  
Removing the feedback loop reduced complexity and cost, making current sensors more accessible for cost-sensitive markets. LEM's [HLSR Series](#) embodied this breakthrough with a compact, PCB-mounted (printed circuit board) design that accelerated adoption.
3. *The HMSR series*  
Pushing further, LEM introduced the [HMSR Series](#), a line of high-insulated ICSs

balancing cost efficiency, accuracy, and miniaturization. Key features include:

- Reinforced insulation for high-voltage applications
- Low-resistance primaries to reduce power losses
- Proprietary ASICs for precise signal conditioning
- A miniature ferrite core for improved magnetic immunity
- Integrated over-current detection

These analog HMSR sensors quickly became trusted components in both DC and AC applications where compactness, bandwidth (up to 300 kilohertz), and noise immunity were essential.

### A digital shift: introducing the benefits of the HMSR DA

As industries undergo digital transformation, current sensing must evolve as well. With the launch of the [HMSR DA Series](#), the first integrated current sensor with a Sigma-Delta bitstream output, LEM has taken a decisive step into the digital domain. This has profound implications for performance, design flexibility, and system integration across multiple industries.

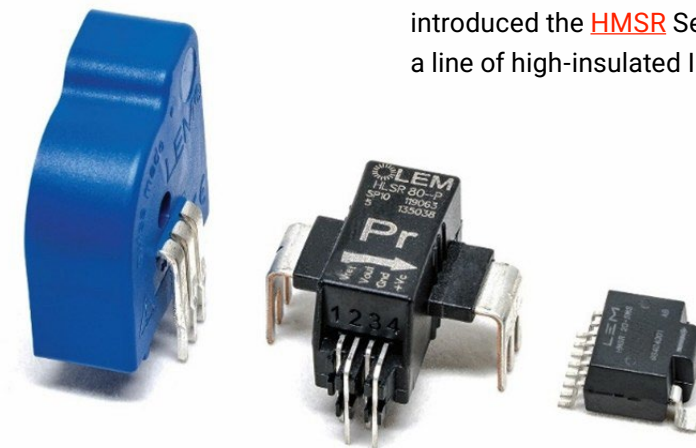

The miniaturization of current sensors. *Image source: LEM*

HMSR DA effective resolution vs  $I_{PN}$

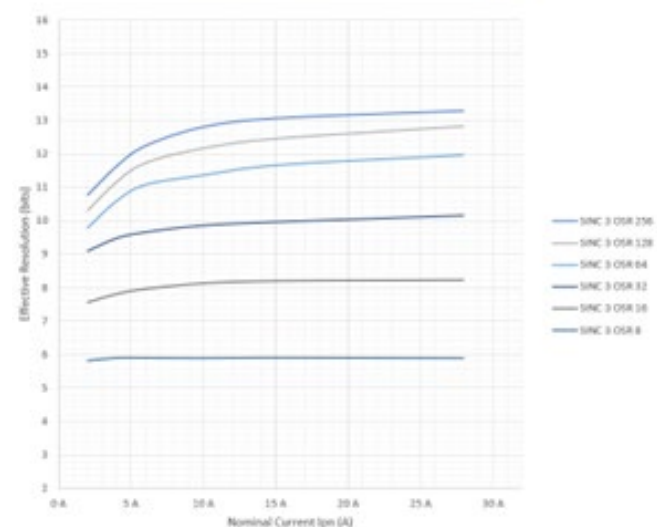

HMSR DA resolution vs OSR (sinc3)

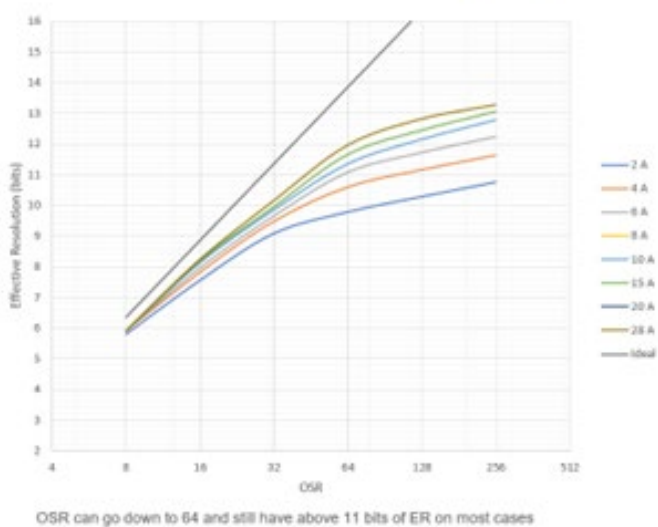

### Why Sigma-Delta modulation matters

A Sigma-Delta Modulator (SDM) converts an analog signal into a high-frequency, serial digital stream. For ICSs, this approach offers clear advantages:

- Reduced quantization noise**  
Unlike standard analog-to-digital converters, the SDM spreads noise across frequencies, allowing digital filters to extract a cleaner, high-resolution signal.
- Predictable response time**  
While a fixed delay (settling time) is introduced, it remains consistent and manageable.
- Design flexibility**  
Users can prioritize either high resolution (using higher-order filters) or faster response (with low-order filters).

- Integration efficiency**  
SDMs fit seamlessly into complementary metal-oxide semiconductor (CMOS) processes, reducing system complexity and cost.

With a 10 megahertz (MHz) clock and an oversampling ratio of 128, the HMSR DA achieves a settling time of approximately 38.4 microseconds – fast enough for demanding applications while maintaining 11-13 bits of resolution.

### System simplification

Traditionally, isolated digital current measurement required multiple parts: a shunt resistor, a digital isolator, and multiple power supply elements. This increases cost and the consumed PCB space exposes systems to noise vulnerabilities.

The HMSR DA replaces this entire assembly with a single compact

sensor. Beyond consolidation, it also integrates ASIC-based intelligence and built-in over-current detection – capabilities conventional setups cannot easily replicate.

### Flexible outputs for smarter design

The HMSR DA also introduces greater output flexibility:

- Single-ended output**  
Straightforward Sigma-Delta bitstream with clock.
- Differential output**  
This supports RS-422 and LVDS (Low-Voltage Differential Signaling) receivers, eliminating the need for external drivers. Differential signaling provides inverted outputs for both signal and clock, ensuring noise cancellation at high speed and low power.

This flexibility allows engineers to tailor systems for precision, response time, or maximum immunity depending on application requirements.

### Where digital ICSs deliver the most value

Digital-output ICSs, like the HMSR DA, provide the biggest benefits in noisy environments where analog signals can degrade.

- Robotics and servo drives**  
Precise, noise-immune current measurement is critical for motor control.
- CNC machine tools and textile machinery**  
Compact, high-resolution sensors fit seamlessly into space-constrained systems.
- Welding equipment and automated guided vehicles**  
Applications that demand robust insulation and resilience against electrical disturbances benefit directly from digital signaling.

- Automotive applications**  
As the automotive sector is rapidly electrifying, digital ICSs address long-standing challenges with noise and magnetic interference. From onboard chargers to traction inverters, digital signaling ensures cleaner, more reliable current measurement.

### Looking ahead: what comes next for LEM's digital ICs

The history of ICSs has always been defined by two forces: anticipating customer needs and advancing technology to meet them. While the adoption of digital ICSs is still in its early stages, the trend is clear. As industries push for smaller, cleaner, and more cost-efficient solutions, digital output will become a new standard.

The HMSR DA is the foundation of LEM's digital sensor strategy – a breakthrough that unites Sigma-Delta bitstream output with proven insulation, compact packaging, and integrated protection features.

This combination not only simplifies system design but also gives engineers the flexibility to prioritize precision, speed, or noise immunity based on their application requirements.

Today, the HMSR DA supports continuous currents of 30-36 A (35 A peak). Future generations will expand toward 100 A continuous, all while remaining PCB-mountable and compact. Looking further ahead, the planned elimination of the magnetic microcore will unlock faster frequency response and complete immunity to magnetic disturbances – removing one of the final limitations of analog design.

The HMSR DA is the first step of a digital roadmap that will redefine current sensing for the next decade and beyond.

[Visit the DigiKey website](#) for more information on how LEM is supporting the growing demand for smarter, more energy-efficient electronic solutions.

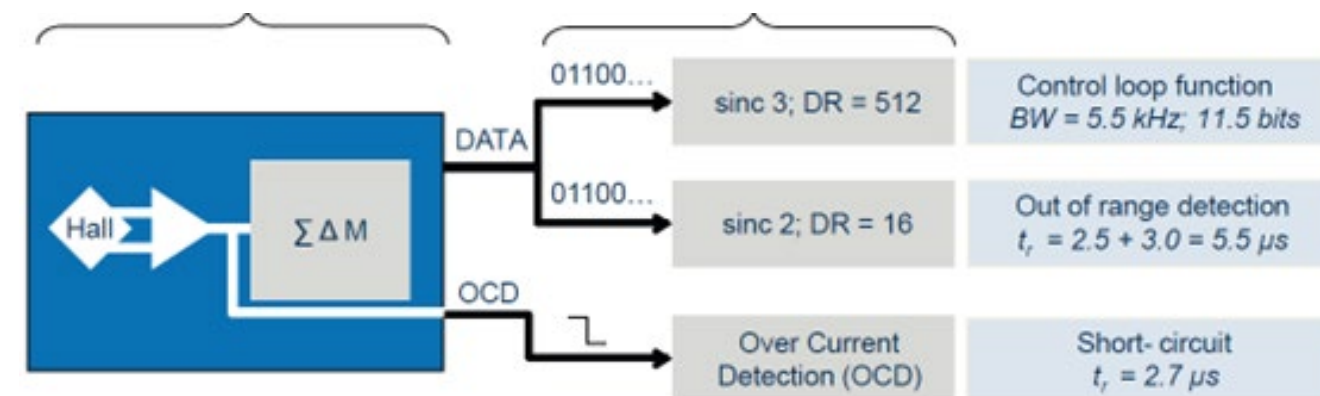

A young woman with curly hair is shown in profile, drinking water from a clear glass. She is wearing a white t-shirt and a hoop earring. The background is a kitchen with a white wall and a black range hood.

## Using hydrostatic level sensors to improve the efficiency of fresh water processing

By Jeff Shepard

Clean, fresh water is vital. Drinking water processing plants are found almost everywhere. To operate efficiently, those plants need to monitor the available water level in wells, storage tanks, rivers, reservoirs, and other areas.

Depending on the application and operating conditions, water levels can be monitored using mechanical devices like floats or solid-state devices like hydrostatic level sensors. Some technologies are more suited for point-level applications to monitor specific level thresholds and prevent spills. In contrast, others are suited for continuous level measurements in process control and inventory management systems.

This article begins with an overview

of point-level and continuous-level monitoring applications. It then presents the operating principles of hydrostatic level sensors and reviews some uses of those sensors in drinking water processing plants.

It briefly looks at how the U.S. Environmental Protection Agency (EPA) keeps track of freshwater consumption using an “abstraction register.” It then reviews some available hydrostatic level sensors from [Endress+Hauser](#). It closes with application suggestions when integrating sensors into critical infrastructure installations like drinking water processing facilities.

Float-level sensors are simple mechanical devices. The float rises and falls along with the level of

the water. That motion opens and closes a mechanical switch that indicates when a specific water level has been passed. These sensors are often used to prevent tanks from getting too full and spilling water or getting too low and damaging pumps or other equipment.

Hydrostatic level sensors provide a continuous measurement of the water level. They are commonly used in storage and processing tanks and vessels in freshwater processing plants. As the vessel fills or drains, the weight of the water above the hydrostatic level sensor changes, and the sensor produces a height-dependent output (Figure 1). That makes them especially useful for process control applications.

## Using hydrostatic level sensors to improve the efficiency of fresh water processing

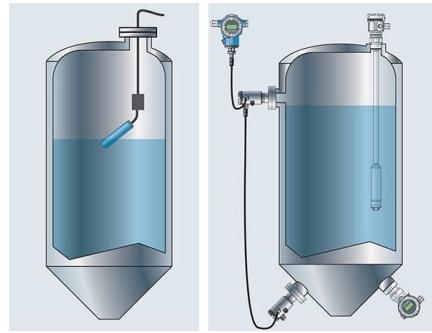

Figure 1: Float sensors move up and down (left) and can monitor specific levels in a tank, while hydrostatic sensors are stationary and provide continuous level monitoring (right).

Image source: Endress+Hauser

Hydrostatic level sensors measure the pressure of the water column above the diaphragm on the bottom of the sensor. An incompressible hydraulic oil transmits the pressure from the diaphragm to the sensor mechanism. The surface interface between the hydraulic oil and the water is relatively large, and the pressure is focused on a smaller column that reaches the sensor mechanism. The

sensing mechanism consists of a Wheatstone bridge that changes resistance as the substrate is deflected (Figure 2).

Hydrostatic level sensors combine high reliability with very low installation costs. Their applications range from freshwater processing plants, where they ensure efficient operation, to monitoring local water ecosystems to ensure long-term water availability.

### Freshwater processing

Water abstraction (water withdrawal, extraction, and intake) is the first step in delivering drinking water. It's the process of taking water from any source. The amount of available water is closely monitored using devices like hydrostatic level sensors.

The rest of the freshwater processing details vary based on local regulations, but monitoring water levels is needed throughout

the plant. Some common steps include (Figure 3):

- Coagulation is implemented by adding chemicals with a positive charge to the water to neutralize the negative charge of dirt and other dissolved particles
- Flocculation involves a second chemical process where the coagulated particles form larger particles called flocs
- Sedimentation is where the flocs settle to the bottom of the water, and the sludge is removed
- Filtration is where various filters remove remaining dissolved particles and germs
- Disinfection uses chlorine or chloramine to kill parasites, bacteria, viruses, and germs
- Storage and distribution. Freshwater processing is a continuous process, but in most

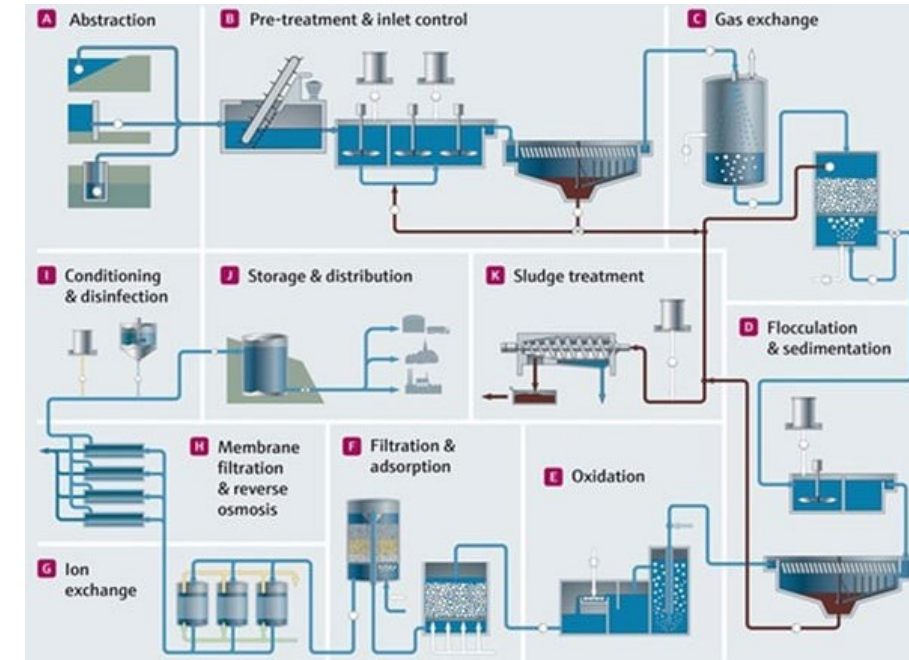

Figure 3: Potable water treatment can include many processes that must be monitored closely to ensure water quality and compliance with legal regulations.

Image source: Endress+Hauser

cities, water usage peaks in the morning and evening, requiring large storage facilities to match the availability of fresh water to the demand

### Abstraction register

Adequate water availability is necessary to ensure efficient freshwater processing. Environmental legislation controls raw water abstraction from natural sources to avoid damage to the local water balance.

In Europe, maintaining adequate water levels and flows is dictated by the Water Framework Directive, which focuses on the quantitative and qualitative management of natural water resources. In the

U.S., the EPA has similar goals and closely monitors water abstraction.

The EPA collects information about the amount of water abstraction, together with information about water discharges, to assess the risk of over-abstraction. The data is reported in an annual [abstraction register](#). Hydrostatic level sensors are important tools for monitoring local water ecosystems' health.

### Hydrostatic level sensors

Hydrostatic level sensors are highly versatile devices. Typical applications include:

- Monitoring levels in rivers, lakes, gauging stations, and reservoirs

- Ensuring drinking water availability in water towers and storage tanks
- Measuring water level in wells

The compact 22 mm diameter of Endress+Hauser [Waterpilot FMX11](#) submersible hydrostatic level sensors makes them easy to integrate. These sensors provide a 4 to 20 mA output signal compatible with data loggers, panel meters, programmable logic controllers (PLCs), and other process control equipment.

Waterpilot FMX11 hydrostatic level sensors have several drinking water certifications, including National Sanitation Foundation 61 (NSF-61) in the U.S., Attestation de Conformité Sanitaire (ACS) in France, and TZW:VVGW - Technologiezentrum Wasser in Germany.

The housing is made of 316 alloy stainless steel and is approved



Figure 4: Waterpilot hydrostatic level sensors have several international certifications for drinking water applications and are made using FDA-approved materials.

Image source: DigiKey

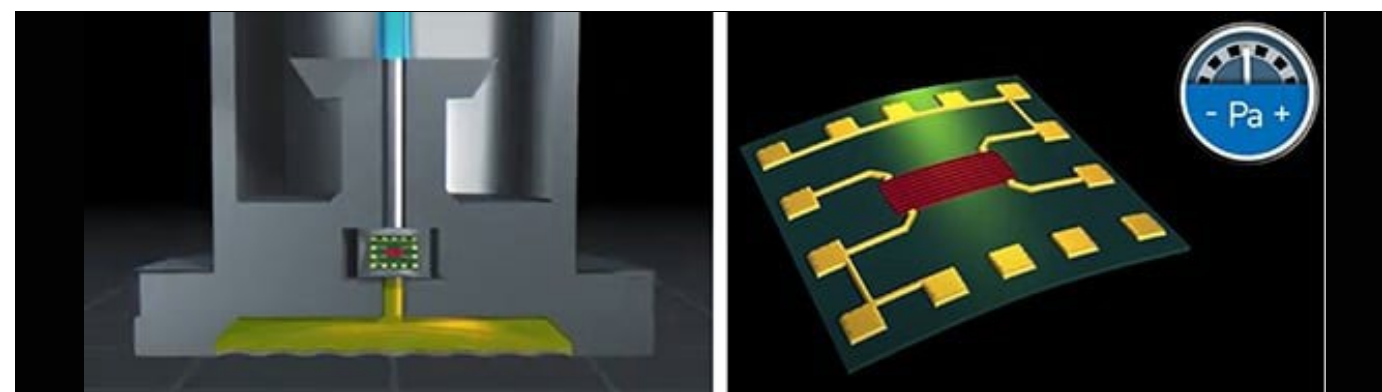

Figure 2: Internal structure of a typical hydrostatic level sensor (left) and a representation of the Wheatstone bridge sensing mechanism being deflected (right)

Image source: Endress+Hauser

## Using hydrostatic level sensors to improve the efficiency of fresh water processing

for drinking water applications by the Food and Drug Administration (FDA). The shielded extension cable includes an atmosphere pressure compensation tube with a Teflon filter in an abrasion- and ultraviolet (UV) light-resistant thermoplastic elastomer (TPE) jacket. TPE and Teflon are also FDA-approved for drinking water applications (Figure 4).

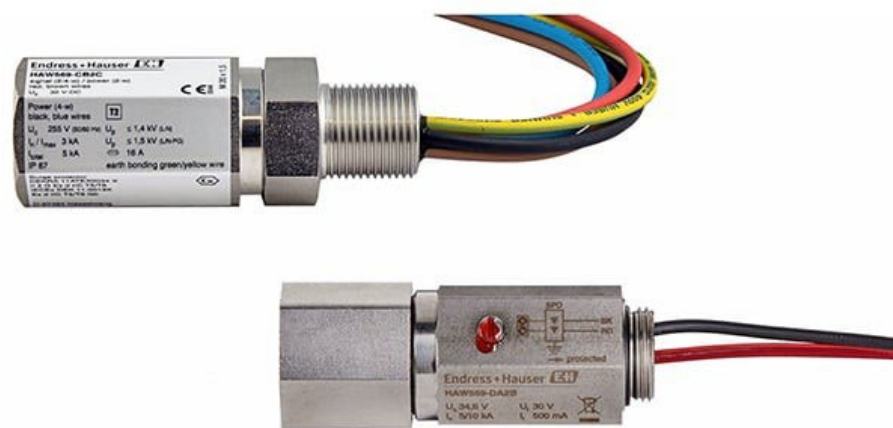

Figure 5: HAW569-CB2C for power and signal cables (top) and HAW569-DA2B for signal cables (bottom). Image source: Endress+Hauser

### General specifications:

- Operating temperature range of -10°C to +70°C
- IP68 protection
- Accuracy of  $\leq \pm 0.35\%$  for sensor measuring range  $\geq 400\text{mbar}$
- Accuracy of  $\leq \pm 0.50\%$  for sensor measuring range  $< 400\text{mbar}$
- cULus certification

### Available models:

- FMX11-CA11DS06** with a sensing range of 0 to 0.2 bar (6.7 ft of water column) and a 6m cable
- FMX11-CA11FS10** with a sensing range of 0 to 0.4 bar (13.4 ft of water column) and a 10m cable
- FMX11-CA11GS20** with a sensing range of 0 to 0.6 bar (20.1 ft of water column) and a 10m cable

- FMX11-CA11HS20** with a sensing range of 0 to 1 bar (33.5 ft of water column) and a 20m cable
- FMX11-CA11KS30** with a sensing range of 0 to 2 bar (66.9 ft of water column) and a 30m cable

### Maximizing water processing plant availability

Drinking water processing plants are critical infrastructure and require high levels of reliability. Waterpilot FMX11 sensors are tested per the electromagnetic compatibility (EMC) guidelines of EN 1000-4-5 / IEC 61000-4-5, which defines the requirements and methods for testing the ability to withstand power surges.

However, basic EMC testing only covers surges up to 2 kV on main power lines or 1 kV on signal lines. That can be insufficient for critical infrastructure where even indirect

lightning or switching operations can result in surges up to 10 kV within microseconds.

Endress+Hauser recommends the use of surge arresters to ensure plant availability. Surge arresters are available and designed for DIN rail mounting in control cabinets and for direct mounting in a field housing:

- HAW562 surge arresters like the **HAW562-AAD** to protect power and communication lines in control cabinets
- HAW569 surge arresters for process field instrumentation like the **HAW569-CB2C** for power supply and signal cables and the **HAW569-DA2B**, for signal cables (Figure 5)

The recommended installation for maximum availability includes (Figure 6):

- Waterpilot FMX11 hydrostatic level sensor

- HAW surge arresters
- Display and evaluation unit with an input for a 4 to 20 mA sensor signal
- Power supply

The power supply voltage range is 8 VDC to 28 VDC, and current consumption is a maximum of 22 mA and a minimum of 2 mA. When used outdoors, the power supply should be housed in an IP66/IP67-rated terminal box. A circuit breaker that meets the requirements of IEC 61010 is highly recommended.

Waterpilot FMX11 hydrostatic level sensors have integrated reverse polarity protection and will not be damaged if the power cables are connected improperly. In the event of a reverse polarity connection, the device is not operational.

### Safety integrity levels and explosive atmospheres

Hydrostatic level sensors also need to operate safely, even in the presence of explosive atmospheres. IEC 61508 defines safety integrity levels (SILs), and IEC 61511 is an application-specific adaptation of IEC 61508 for the process industry. HAW569

units are designed for use in field instrumentation and meet SIL2 requirements. HAW562 surge arresters are intended for use in less hazardous applications in equipment cabinets and are optionally available with SIL2.

The situation is similar to that used in explosive (Ex) atmospheres. HAW562 surge arresters are optionally available with Ex intrinsically safe approvals. Two common Ex certifications are Ex ia and Ex d.

Ex ia certification delivers intrinsically safe protection that ensures the maximum internal energy of the device and its wiring remains below the energy level required to cause ignition, even in the event of a fault. It's intended for use in areas where an explosive gas mixture is present for extended periods or continuously and poses a significant hazard.

Ex d certified devices are designed to withstand an internal explosion without sustaining damage. These devices are intended for use in critical areas where an explosive gas mixture will likely occur during normal operation, presenting an intermittent hazardous condition.

HAW569 units designed to protect signal cables are optionally available with Ex ia approval, while Ex d approval is an option on those designed for the simultaneous protection of signal and power cables. HAW562 surge arresters are also available with optional Ex intrinsically safe approvals.

### Conclusion

There are several applications for hydrostatic level sensors, including process control and inventory management in drinking water processing plants, as well as monitoring water sources like wells, rivers, lakes, and reservoirs to ensure water availability and sustainability. Drinking water processing plants are critical infrastructure and must be adequately protected to ensure continuous operation.

Waterpilot FMX11 hydrostatic level sensors are made using FDA-approved materials for drinking water applications and have several related international approvals. Endress+Hauser also recommends using surge arresters and offers models with SIL2 performance and Ex ia and Ex d certifications for Waterpilot FMX11 sensors.

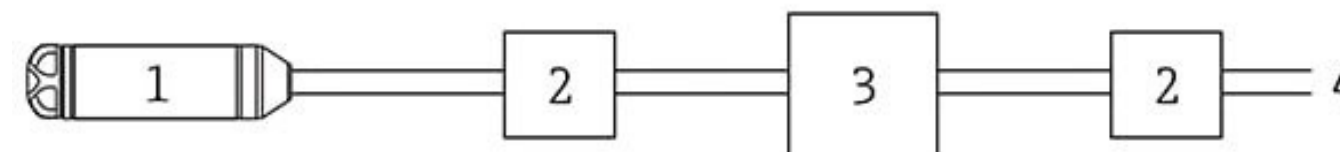

Figure 6: Waterpilot FMX installation block diagram showing the positions of the two surge arresters (2).

Image source: Endress+Hauser

# This month in history

1752

May 10

## Benjamin Franklin tests lightning rod

Founding father and inventor Benjamin Franklin conducted the first test of his lightning rod. By erecting a metal rod to draw lightning safely to ground, Franklin proved that pointed iron rods could “disarm” lightning clouds. This key experiment in electrical science led to widespread use of lightning rods to protect buildings from strikes.

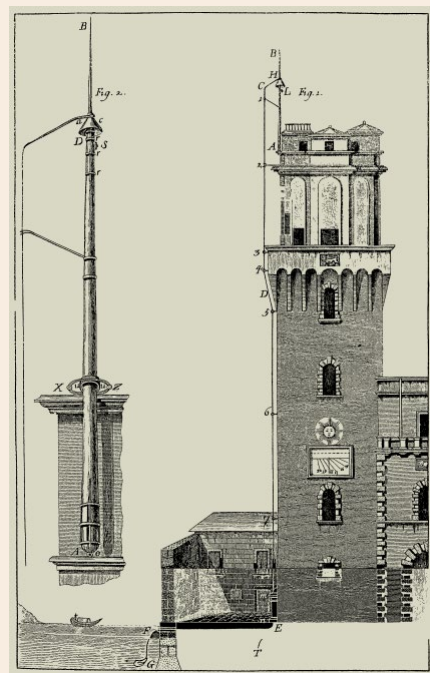

Drawings of early lightning rod designs.

1827

May 1

## The Galvanic Circuit investigated mathematically

German physicist Georg Simon Ohm released his treatise *Die galvanische Kette* (The Galvanic Circuit) detailing the law linking voltage, current, and resistance. Ohm’s work, stating that  $V = I \times R$ , quantified how electric current flow is impeded by resistance. Initially overlooked, Ohm’s Law became a foundation of electrical engineering and circuit design.

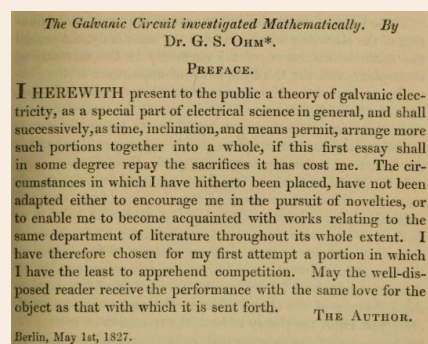

The preface to Ohm’s seminal work, outlining the mathematical tools essential for the next two centuries of technology.

1876

May 10

## Telephone debuts at World’s Fair

Alexander Graham Bell showcased his telephone to the public at the U.S. Centennial Exposition in Philadelphia. Crowds at the world’s fair could hear Bell’s voice carried over a wire, a novelty that proved speech could be electrically transmitted. This first public demonstration of the telephone marked the beginning of a new era in global communication.



Alexander Graham Bell demonstrating the telephone to the World’s Fair.

1891

May 20

## Tesla’s wireless lighting demo

Nikola Tesla gave a famous lecture to the AIEE in New York titled “Experiments with Alternate Currents of Very High Frequency”. Tesla vividly demonstrated wireless lighting by transmitting power through the air to illuminate Geissler tubes and lamps without wires, using his new Tesla coil to produce high-frequency, high-voltage currents.

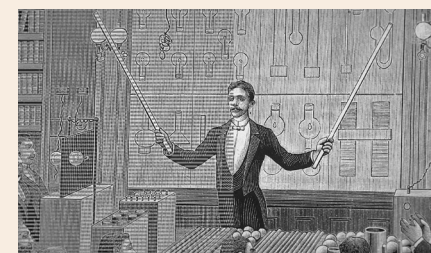

Tesla demonstrating wireless power transmission.

1978

May 3

## The first unsolicited “spam” email is sent

The earliest instance of email spam was when marketing manager Gary Thuerk sent an unauthorized mass email to every West Coast ARPANET user, 393 users. Thuerk’s message advertised a new Digital Equipment Corp. computer. The reaction was largely negative, and administrators frowned on the breach of etiquette. Though unwelcome, this event proved electronic messaging could be used for advertising.



In an unprecedented move, Gary Thuerk at DEC invented the Spam Email.

1980

May 22

## Pac-Man arcade game is released

The iconic video game Pac-Man made its debut in Japanese arcades. Developed by Namco and originally called “Puck Man,” the maze-chase game was location-tested in a Tokyo cinema and met with instant popularity. Unlike the violent space shooters of the day, Pac-Man’s cute characters and simple gameplay drew in broad audiences. Pac-Man was the first video game to become a mainstream pop icon, spawning merchandise, an animated TV show, a hit song, and multiple Sega Genesis games.



A Japanese promotional poster for the original ‘Puck Man’ arcade game.



Today's  
newest  
products =  
tomorrow's  
innovations

[digikey.com/new](https://www.digikey.com/new)

**DigiKey**

**we get technical**

DigiKey is an authorized distributor for all supplier partners. New products added daily. DigiKey and DigiKey Electronics are registered trademarks of DigiKey Electronics in the U.S. and other countries. © 2026 DigiKey Electronics, 701 Brooks Ave. South, Thief River Falls, MN 56701, USA

 **ECIA MEMBER**  
Supporting The Authorized Channel